

# Series 4000

## *Application Guide*

**Part Number: 27249-00**

**Revision: A**

**Date: February 1995**

*Trimble Navigation Limited  
Surveying & Mapping Division  
645 North Mary Avenue  
Post Office Box 3642  
Sunnyvale, CA 94088-3642  
U.S.A.*

*+1-800-827-8000 in North America  
+1-408-481-8000 International  
FAX: +1-408-481-8214*

---

*Trimble Navigation Europe Limited  
Trimble House, Meridian Office Park  
Osborn Way, Hook  
Hampshire RG27 9HX  
ENGLAND  
+44-1256-760-150  
FAX: +44-1256-760-148*

*Trimble Navigation Singapore PTE Limited  
300 Beach Road  
#34-05, The Concourse  
Singapore 199555  
SINGAPORE  
+65-296-2700  
FAX: +65-296-8033*

*Trimble Japan K.K.  
Sumitomo Hamamatsu-cho, Building 10F  
1-18-16 Hamamatsu-cho Minato-ku  
Tokyo 105  
JAPAN  
+81-3-5472-0880  
FAX: +81-3-5472-2326*

*Trimble Navigation New Zealand Limited  
11 Birmingham Drive  
P.O. Box 8729 Riccarton  
Christchurch  
NEW ZEALAND  
+64-3-339-1400  
FAX: +64-3-339-1417*

## **Copyrights**

© 1996 Trimble Navigation Limited. All rights reserved. No part of this manual may be copied, photocopied, reproduced, translated, or reduced to any electronic medium or machine-readable form without prior written consent from Trimble Navigation Limited.

Printed in the United States of America. Printed on recycled paper.

---

## **Revision Notice**

This is the second release of the Series 4000 Application Guide, Part Number 272494-00, Revision B, February 1996. This guide describes receiver firmware version 7.10.

## **Trademarks**

4000 Download, 4000A, 4000DS, 4000DSR, 4000RS, 4000RSR, 4000S, 4000SE, 4000SSE, 4000SSi, 4000ST, Asset Surveyor, DeltaNav QC, Dual-Frequency, FastStatic, Geodetic Surveyor, Geodetic Surveyor SSi, Geodetic System Surveyor, Geodetic System Surveyor SSi, GIS Surveyor, GPSurvey, HYDRO, Land Surveyor II, Land Surveyor IID, PFINDER, PostNav II, RTK, Seismic Controller, Single-Frequency, Site Surveyor SSi, Super-trak, Survey Controller, System Surveyor II, TDC1, TRIMTALK 900, TRIMVEC Plus are trademarks of Trimble Navigation Limited. IBM is a registered trademark of International Business Machines, Inc. Microsoft and MS-DOS are registered trademarks of Microsoft Corporation. Windows is a trademark of Microsoft Corporation. All other brand names are trademarks of their respective holders.

## **Patents**

The Series 4000 receivers are covered by the following U.S. patents: 4754465, 4847862, 5148179, 5202694, 5296861, 5357527, 5359332, and other patents pending.

## **Disclaimer of Warranty**

Except as indicated in "LimitedWarranty" herein, Trimble Hardware, Software, Firmware and documentation is provided "as is" and without express or limited warranty of any kind by either Trimble or anyone who has been involved in its creation, production, or distribution including but not limited to the implied warranties of merchantability and fitness for a particular purpose. The entire risk, as to the quality and performance of the Trimble Hardware, Software, Firmware and documentation, is with you. Some states do not allow the exclusion of implied warranties, so the above exclusion may not apply to you.

---

## **Limitation of Liability**

Because the Software is inherently complex and may not be completely free of errors, you are advised to verify your work. In no event will Trimble or any person involved in the creation, production, or distribution of the Trimble Software be liable to you on account of any claim for any damages, including any lost profits, lost savings, or other special, incidental, consequential, or exemplary damages, including but not limited to any damages assessed against or paid by you to any third party, arising out of the use, liability to use, quality or performance of such Trimble Software and documentation, even if Trimble or any such person or entity has been advised of the possibility of damages, or for any claim by any other party. Some states do not allow the limitation or exclusion of liability for incidental or consequential damages so, the above limitations may not apply to you.

## **Software and Firmware Limited Warranty**

Trimble warrants that Software and Firmware products will substantially conform to the published specifications provided it is used with the Trimble products, computer products, and operating system for which it was designed. For a period of ninety (90) days, commencing thirty (30) days after shipment from Trimble, Trimble also warrants that the magnetic media on which Software and Firmware are distributed and the documentation are free from defects in materials and workmanship. During the ninety (90) day warranty period, Trimble will replace defective media or documentation, or correct substantial program errors at no charge. If Trimble is unable to replace defective media or documentation, or correct program errors, Trimble will refund the price paid for The Software. These are your sole remedies for any breach in warranty.

## **Hardware Limited Warranty**

Trimble Navigation Limited products are warranted against defects in material and workmanship for a period of one year. The warranty period shall commence thirty (30) days after shipment from Trimble's factory. Warranty service will be provided at a designated Trimble Service Center. Trimble will at its option either repair or replace products that prove to be defective. The Customer shall pay all shipping charges for products returned to Trimble for warranty service. Trimble shall pay all shipping charges for the return of products to the Customer.

The above warranty shall not apply to defects resulting from:

1. Improper or inadequate maintenance by the buyer
2. Buyer-supplied software or interfacing
3. Unauthorized modification or misuse
4. Operation outside of the environmental specifications of the product

- 
5. Improper installation, where applicable
  6. Lightning or other electrical discharge
  7. Fresh or salt water immersion or spray
  8. Normal wear and tear on consumable parts (for example, batteries)

No other warranty is expressed or implied. Trimble Navigation Limited specifically disclaims the implied warranties of fitness for a particular purpose and merchantability.

## **Notices**

**Electrical safety.** Power adapters such as the Office Support Module 2 (OSM2) contain high AC voltages when operating. Please read and obey the instructions for their use.

**Class A Computing Device—Information to User.** This equipment has been tested and found to comply with the limits for a Class A digital device, pursuant to Part 15 of the FCC Rules. These limits are designed to provide reasonable protection against harmful interference when the equipment is operated in a commercial environment. This equipment generates, uses, and can radiate radio frequency energy and, if not installed and used in accordance with the instruction manual, may cause harmful interference to radio communications. Operation of this equipment in a residential area is likely to cause harmful interference, in which case the user will be required to correct the interference at his own expense.

**GPS service subject to change without notice.** The U.S. government has stated that present GPS users do so at their own risk and that the government may change or end operation of these satellites at any time and without warning.

Advisory Notice: Some of the receivers described in this manual use the GPS P-code signal, which by U.S. policy may be encrypted or switched off without notice.

---

---

# Table of Contents

---

I

## **Preface**

Scope and Audience . . . . .	xvii
Organization . . . . .	xviii
Related Information . . . . .	xix
Update Notes. . . . .	xx
Bulletin Board Service. . . . .	xx
Technical Assistance. . . . .	xx
FaxBack . . . . .	xxi
Reader Comment Form . . . . .	xxi
Document Conventions . . . . .	xxi
Notes, Tips, Cautions, and Warnings. . . . .	xxii

## **1 Introduction**

1.1	Notes on Terminology . . . . .	1-1
1.2	Applications and Procedures . . . . .	1-2
1.2.1	Control Surveying . . . . .	1-5
1.2.2	Topographic Surveying . . . . .	1-6
1.2.3	Stakeout . . . . .	1-7
1.2.4	Precision Positioning . . . . .	1-8
1.2.5	Navigation . . . . .	1-8
1.2.6	GIS Data Acquisition . . . . .	1-8

1.3 How to Use Your Receiver's Manuals . . . . . 1-11  
1.4 Additional Sources of Information . . . . . 1-12

## 2 Static Surveying

2.1 Equipment and Software Required. . . . . 2-2  
2.2 Setting Up the Equipment . . . . . 2-3  
2.3 Other Applications of Static Surveying . . . . . 2-4  
    2.3.1 Running a Quickstart Survey . . . . . 2-6  
        How to Inspect or Modify the Quickstart Controls . . . . . 2-6  
        How to Start a Quickstart Session . . . . . 2-8  
        Importance of Simultaneous Observations . . . . . 2-9  
        How to End a Quickstart Session . . . . . 2-9  
    2.3.2 Defining a Preplanned Static Survey . . . . . 2-12  
        Step 1: Select or Define a Station Description. . . . . 2-13  
        Step 2: Enter the Station's Reference Position. . . . . 2-14  
        Step 3: Select or Define a Session Description . . . . . 2-15  
        Step 4: Set Special Controls . . . . . 2-17  
        Step 5: Schedule the Session. . . . . 2-19  
        Step 6: Set Additional Parameters . . . . . 2-20  
        Step 7: Add Another Session . . . . . 2-21  
        Step 8: Add Another Station. . . . . 2-22  
    2.3.3 Running a Preplanned Survey . . . . . 2-24  
    2.3.4 Entering Antenna Information During a Survey. . . . . 2-26  
        How to Enter Field Notes or Event Marks During a Survey 2-27  
        How to End a Preplanned Survey . . . . . 2-28  
    2.3.5 Using the Auto-Survey Timer . . . . . 2-28  
        When Scheduled Sessions Are Run . . . . . 2-29  
        How to Enable the Auto-Survey Timer . . . . . 2-29  
        How to Cancel the Auto-Survey Timer . . . . . 2-31



2.3.6 Performing Other Operations During a Static Survey . . . 2-32  
 2.4 Static Surveying and DGPS at the Same Time. . . . . 2-34

**3 FastStatic Surveying**

3.1 Required Equipment and Software. . . . . 3-2  
 3.2 Setting Up the Equipment . . . . . 3-2  
     3.2.1 Setting the Operating Parameters . . . . . 3-5  
         Importance of Simultaneous Observations . . . . . 3-7  
     3.2.2 Performing a FastStatic Survey . . . . . 3-7  
         Step 1: Display the Main FastStatic Screen . . . . . 3-8  
         Step 2: Set Up the Antenna . . . . . 3-10  
         Step 3: Start an Observation . . . . . 3-10  
         Step 4: Enter Mark ID and Antenna Parameters. . . . . 3-11  
         Step 5: Wait While the Receiver Collects Data . . . . . 3-12  
         Step 6: End the Observation . . . . . 3-13  
     3.2.3 Aborting an Observation. . . . . 3-14  
     3.2.4 Displaying Satellite Tracking Information. . . . . 3-15  
     3.2.5 Creating a Log Data File for Each Observation . . . . . 3-17  
     3.2.6 Turning Power Off Between Marks . . . . . 3-17

**4 Kinematic Surveying**

4.1 Planning for a Kinematic Survey. . . . . 4-5  
     4.1.1 Reference Marks. . . . . 4-5  
     4.1.2 Number of Receivers. . . . . 4-5  
     4.1.3 Satellite Availability . . . . . 4-6  
     4.1.4 Assigning Point IDs . . . . . 4-6  
 4.2 Equipment and Software Required. . . . . 4-7  
 4.3 Notes on Using a Survey Controller or Seismic Controller . . . . . 4-9  
 4.4 Setting Parameters . . . . . 4-9

## Table of Contents

---

4.4.1	General Parameter Settings . . . . .	4-10
4.4.2	Positioning Mode Parameters . . . . .	4-10
4.4.3	Kinematic Data Logging Parameters . . . . .	4-11
4.5	Initializing a Kinematic Survey . . . . .	4-12
4.5.1	How to Initialize by Occupying a Fixed Baseline . . . . .	4-13
4.5.2	How to Initialize by Swapping Antennas . . . . .	4-15
4.6	Using Multiple Base Stations . . . . .	4-18
4.7	Performing a Stop-and-Go Kinematic Survey . . . . .	4-19
4.8	Performing a Continuous Kinematic Survey. . . . .	4-21
4.9	Ending a Survey . . . . .	4-22
4.10	Reading the Main Kinematic Screen. . . . .	4-23
4.11	Aborting an Observation . . . . .	4-24
4.12	Reinitializing a Surve . . . . .	4-24
4.12.1	To Return to a Previous Survey Mark . . . . .	4-25
4.12.2	To Perform an Initialization Procedure . . . . .	4-25
4.12.3	Delaying Reinitialization . . . . .	4-26
4.12.4	Setting the Kinematic Alarm's Volume . . . . .	4-27
4.12.5	Loss of Lock at the Base Station. . . . .	4-27

## 5 Differential GPS

5.1	Equipment and Software Required. . . . .	5-3
5.2	Outlines of the Configuration Process . . . . .	5-4
5.3	Steps in the Configuration Process. . . . .	5-6
5.3.1	Setting the Elevation and PDOP Masks and Sync Time. . . . .	5-6
	Sync Time and the Radio's Transmit Duty Cycle . . . . .	5-9
5.3.2	Setting the Receiver's Reference Position . . . . .	5-10
5.3.3	Disabling RTCM-104 Input and Output and Other Outputs . . . . .	5-12
5.3.4	Configuring a Serial Port . . . . .	5-14
5.3.5	Enabling RTCM-104 Input or Output . . . . .	5-14

5.3.6 Setting Up the Modem and Radio . . . . . 5-17

5.3.7 Connecting the Serial Port to the Other Device . . . . . 5-18

5.3.8 Running the Data Logging Program (Only with Memory Option). . . . . 5-18

5.3.9 Starting Data Logging (Only with Memory Option) . . . 5-18

5.4 What Is Different During Data Logging . . . . . 5-19

5.5 Stopping Data Logging. . . . . 5-20

5.6 Downloading Logged Data. . . . . 5-22

5.7 Making Use of Position Data . . . . . 5-22

**6 Navigation**

6.1 Displaying Your Position. . . . . 6-2

6.2 Using the Navigation Screens . . . . . 6-5

6.2.1 NAVIGATE without Navigation Package Option . . . . 6-6

6.2.2 NAVIGATE with Navigation Package Option. . . . . 6-7

    How to Plan Courses and Waypoints . . . . . 6-7

    How to Use the Main NAVIGATION Screen. . . . . 6-9

    How to Change Units of Distance . . . . . 6-11

    How to Display and Set Waypoints . . . . . 6-12

    How to Select a Leg Line . . . . . 6-14

6.3 Displaying Your Velocity . . . . . 6-16

**7 GIS Data Acquisition**

7.1 Summary of the Procedure. . . . . 7-2

7.2 Equipment and Software Required. . . . . 7-3

**A Common Operations**

A.1 Connectors and Cables . . . . . A-1

    A.1.1 How to Supply Power to a Portable Receiver . . . . . A-1

## Table of Contents

---

A.1.2	How to Draw Power from a Portable Receiver . . . . .	A-5
A.2	Connecting a Serial Port to Another Device . . . . .	A-6
A.2.1	Choice of Data Cable . . . . .	A-6
A.2.2	How To Configure a Serial Port . . . . .	A-7
A.2.3	How to Use a Remote Protocol . . . . .	A-9
A.3	Setting the Power-Up Parameters to Their Defaults . . . . .	A-10
A.4	Configuring Single or Dual-Frequency Operation . . . . .	A-12
A.5	Entering Supplementary Data . . . . .	A-13
A.5.1	How to Enter Event Marks and Comments (Only with Event Marker Input Option) . . . . .	A-15
A.5.2	How to Enter Field Notes . . . . .	A-17
A.5.3	How to Enter Surface Meteorological Data . . . . .	A-18
A.6	Adjusting Local Time Zone and Time Displays . . . . .	A-19
A.6.1	Local Time Zone and Time Offset . . . . .	A-19
A.6.2	Time Display Format . . . . .	A-20
A.7	Using Local Datums and Projections . . . . .	A-20
A.7.1	How to Select a Local Datum or Local Zone . . . . .	A-21
A.8	Using and Caring for an Antenna . . . . .	A-22
A.8.1	Tripod with Tribrach . . . . .	A-22
A.8.2	Fixed-Height Tripod . . . . .	A-30
A.8.3	Rangepole . . . . .	A-30
	Setup. . . . .	A-31
A.8.4	Quick-Release Adapter and Bayonet . . . . .	A-35
A.8.5	Magnetic Mount . . . . .	A-36
A.8.6	Backpack Antenna Mount . . . . .	A-38
A.8.7	Antenna Cables . . . . .	A-38
A.8.8	Compact Dome Antenna . . . . .	A-38
A.8.9	Modular Antenna . . . . .	A-41
	Setup. . . . .	A-41
	Height measurement. . . . .	A-42

A.8.10	Compact L1/L2 Antenna . . . . .	A-42
A.8.11	Compact L1 Antenna . . . . .	A-44
A.8.12	Permanent Reference Station L1/L2 Geodetic Antenna .	A-45
A.8.13	L1 Geodetic Antenna . . . . .	A-45
A.8.14	L1/L2 Geodetic Antenna and L1/L2 Kinematic Antenna	A-46
A.8.15	4000ST and SST Kinematic Antenna . . . . .	A-46
A.9	Site Preparation and Planning . . . . .	A-47
A.10	Entering Antenna Parameters . . . . .	A-48
A.11	Reading the Main Status Screens . . . . .	A-51
A.11.1	Main Status Screen 1 . . . . .	A-52
A.11.2	Main Status Screen 2 . . . . .	A-55
A.11.3	Main Status Screens 3 and 4 . . . . .	A-56
A.12	Restarting a Session After a Power Failure . . . . .	A-57
A.13	Renaming the Current Data File . . . . .	A-58
A.14	Enabling Cycle Printouts. . . . .	A-59
A.15	Generating Single-Shot Printouts . . . . .	A-62
A.16	External Data Logging (Only with Memory Option) . . . . .	A-63
A.16.1	How to Install LOGST. . . . .	A-63
A.16.2	How to Start Using LOGST in the Shortest Possible Time. . . . .	A-64
A.16.3	Command Line Options for LOGST . . . . .	A-66
A.16.4	Error and Status Displays from LOGST. . . . .	A-71
A.17	Downloading Logged Data. . . . .	A-71
A.17.1	What '4000' Does . . . . .	A-72
A.17.2	How to Install the Downloading Program . . . . .	A-72
A.17.3	How to Get Started with the Downloading Program . .	A-72
A.17.4	How the Receiver and Programs Handle File Names . .	A-75
A.17.5	The "Disk Full" Condition. . . . .	A-78
A.17.6	Merging Split Files and Duplicate Files . . . . .	A-78

**B Troubleshooting Guide**

**Index**

# List of Figures

---

Figure 2-1.	Quickstart Static Survey Procedure . . . . .	2-5
Figure 2-2.	Sessions Process . . . . .	2-11
Figure 2-3.	Preplanned Static Survey Procedure . . . . .	2-23
Figure 3-1.	FastStatic Survey Procedure (Rover) . . . . .	3-3
Figure 4-1.	Initialization for Kinematic Surveying Procedure . . . . .	4-3
Figure 4-2.	Kinematic Surveying Procedure . . . . .	4-4
Figure 6-1.	Sequences of Waypoints Defining Courses . . . . .	6-8
Figure 6-2.	A Network of Waypoints Defining Courses . . . . .	6-9
Figure A-1.	Measuring Uncorrected Antenna Height Directly . . . . .	A-26
Figure A-2.	Measuring Antenna Height Indirectly . . . . .	A-29
Figure A-3.	Rangepole with Support and Antenna . . . . .	A-33
Figure A-4.	Quick-Release Adapter and Bayonet . . . . .	A-36
Figure A-5.	Magnetic Mount . . . . .	A-37
Figure A-6.	Compact Dome Antenna . . . . .	A-39
Figure A-7.	Modular Antenna . . . . .	A-40
Figure A-8.	Compact L1/L2 Antenna with Groundplane . . . . .	A-43
Figure A-9.	Compact L1/L2 Antenna without Groundplane . . . . .	A-43

# List of Tables

---

Table 1-1.	Major Changes in Terminology . . . . .	1-2
Table 1-2.	Series 4000 Applications and Procedures . . . . .	1-3
Table 1-3.	Characteristics of GPS Procedures . . . . .	1-4
Table 1-4.	Series 4000 Procedures and Receivers . . . . .	1-9
Table 1-5.	Series 4000 Procedures and Antennas . . . . .	1-10
Table A-1.	Connectors on the Rear Panel Connectors . . . . .	A-2
Table A-2.	Serial Port Parameters . . . . .	A-9
Table A-3.	Correction Factors for Antenna Height. . . . .	A-34
Table A-4.	ANT TYPE Parameter Values . . . . .	A-51
Table A-5.	Receiver Status on Main Status Screen 1 . . . . .	A-54



# Preface

---

Welcome to the Series 4000 Application Guide. This guide describes all standard applications of Trimble Series 4000 receivers, and the procedures used to perform each of them. Once you are familiar with the basics of operating your receiver, this manual and the appropriate Quick References should be the only Series 4000 manuals you need to take into the field.

## Scope and Audience

Even if you have used other Global Positioning System (GPS) receivers and other minimum shift keying (MSK) receivers we recommend that you spend some time reading this manual. This manual assumes that you are familiar with the basics of operating your Series 4000 receiver. If you are not, read the first few chapters of the receiver's *User Guide*.

This manual also assumes that you are familiar with the principles of the Global Positioning System (GPS), and with the terminology that is used to discuss it. For example, you should understand such terms as *space vehicle (SV)*, *elevation mask*, and *dilution of precision (DOP)*.

If you are not familiar with the GPS, we suggest that you go to your receiver's *User Guide* and read the appendix, "The NAVSTAR Global Positioning System." For more information, see Trimble's booklet *GPS, A Guide to the Next Utility*. You can find a complete citation to that booklet in the Bibliography of the *Series 4000 Receiver Reference*.

To download and postprocess logged data, you should know how to use personal computers running the IBM DOS or MS-DOS operating system. For example, you should be able to run programs, create and use directories, and use common DOS commands such as COPY, REN, and DEL.

The following section provides you with a guide to this manual, as well as to other documentation included with this product.

## Organization

This manual contains the following chapters and appendices:

- Chapter 1, Introduction, briefly describes the applications that Series 4000 receivers typically serve, and the procedures they can perform. It also explains the purposes of the other Series 4000 manuals.
- Chapter 2, Static Surveying, discusses the static surveying procedure.
- Chapter 3, FastStatic Surveying, discusses the FastStatic surveying procedure.
- Chapter 4, Kinematic Surveying, discusses the kinematic surveying procedure.
- Chapter 5, Differential GPS, discusses the differential GPS (DGPS) procedure, with notes on some of its applications.

- Chapter 6, Navigation, discusses navigation with Series 4000 receivers. Navigation is an application rather than a GPS technique, but it has some procedures of its own in addition to the GPS procedures that it uses to compute position fixes.
- Chapter 7, GIS Data Acquisition, discusses techniques for capturing information for use in a GIS database. GIS data acquisition is also an application, but it involves some matters that are best treated apart from the differential GPS procedure which is used to perform it.
- Appendix A, Common Operations, describes certain steps that occur in many of the procedures described in the chapters. Two examples are how to configure a serial port and how to log data externally (on a computer).
- Appendix B, Troubleshooting Guide, gives suggestions for identifying and correcting problems that users of GPS receivers often encounter.
- The Index provides an easy way to find topics in the manual.

Thank you for purchasing this Trimble product. At the end of this manual you will find a reader comment form. We appreciate any feedback you have about this manual.

## Related Information

This manual contains system-wide, general information about the various Series 4000 receivers. The following sections discuss other sources of information.

## **Update Notes**

You will find a Warranty Activation Sheet with your receiver. By sending in your Warranty Activation Sheet, you are automatically sent update notes as they become available. When you receive these packages, read them. They contain important information about software and hardware changes. Contact your local Trimble Dealer for more information about the support agreement contracts for software and firmware, and an extended warranty programs for hardware.

## **Bulletin Board Service**

If you have a modem, check the Customer Support Bulletin Board Service (BBS) on a regular basis for application notes, new software release notices, and other information. The phone number is:

+1-408-481-7800  
protocol: 8, n, 1

## **Technical Assistance**

If you have problems and cannot find the information you need in this document, call the Trimble Technical Assistance Center (TAC). The phone numbers are:

+1-800-SOS-4TAC (in North America)  
+1-408-481-6940 (International)  
+1-408-737-6020 (fax)

You can call the Technical Assistance Center phones between 6 A to 6 PM Pacific Standard Time. A support technician will take your call, help you determine the source of your problem, and provide you with any technical assistance you might need.

## FaxBack

FaxBack is a completely automated fax response system for selecting documents and catalogs (lists of available documents) to be faxed back to a fax machine. Call from a tone-dialing phone and FaxBack guides you through the call by playing a pre-recorded voice message.

The FaxBack system is available 24 hours a day, seven days a week. You can order a variety of documents, including; data sheets, application notes, technical documentation, configuration guides, assembly drawings, and general information.

To call the FaxBack service, dial +1-408-481-7704 and follow the instructions received.

## Reader Comment Form

A reader comment form is provided at the end of this guide. If this form is not available, comments and suggestions can be sent to Trimble Navigation Limited, 645 North Mary Avenue, Post Office Box 3642, Sunnyvale, CA 94088-3642. All comments and suggestions become the property of Trimble Navigation Limited.

## Document Conventions

*Italics* identify software menus, menu commands, dialog boxes, and the dialog box fields.

SMALL CAPITALS identify DOS commands, directories, filenames, and filename extensions.

`Courier` is used to represent what you see printed on the screen by the DOS system or program.

**Courier Bold** represents information that you must type in a software screen or window.

[Return] or [Ctrl] + [C] identifies a hardware function key or key combination that you must press on a PC.

**Helvetica Bold** represents a software command button.

## Notes, Tips, Cautions, and Warnings

Notes, tips, cautions, and warnings are used to emphasize important information.



---

**Note** – Notes give additional significant information about the subject to increase your knowledge, or guide your actions. A note can precede or follow the text it references.

---



---

**Tip** – Indicates a shortcut or other time or labor-saving hint that can help you make better use of the *DSMPro* System.

---



---

**Caution** – Cautions alert you to situations that could cause hardware damage or software error. A caution precedes the text it references.

---



---

**Warning** – Warnings alert you to situations that could cause personal injury or unrecoverable data loss. A warning precedes the text it references.

---

# 1 Introduction

---

This manual applies to all current models of Trimble's Series 4000 GPS receivers. Table 1-4 lists these receivers and the classes of applications they are designed to serve. These are the same models covered by the *Series 4000 Receiver Reference*.

The Series 4000 includes several earlier models, some of which have substantially different hardware and firmware from the receivers in Table 1-4. These receivers are discussed only in individual *Operation Manuals* that predate the current Series 4000 documentation set. The earlier models are the 4000A, AX, S, SX, SXD, SL, SLD, ST, and SST, the Series 4000SE Static Land Surveyor, Kinematic Land Surveyor, and System Surveyor, and the Series 4000RL-II, RL-IIR, DL-II, and DL-IIR.

## 1.1 Notes on Terminology

Series 4000 receivers are used in several different applications that have developed independently of each other, and this has led to a certain amount of inconsistent terminology. For example, in static surveying the point that a receiver's GPS antenna occupies during a satellite observation has traditionally been called a *station*; in FastStatic surveying it has been called a *mark*, and in kinematic surveying it has been called a *point*.

Trimble's documentation has adopted a consistent set of terms as far as it is practical to do so. For the present, this will lead to some inconsistency between documentation and equipment.

Table 1-1 summarizes the major changes in terminology introduced in this manual and its companions. These terms and others are defined in the Glossary of the *Receiver Reference*.

**Table 1-1. Major Changes in Terminology**

<b>New Term</b>	<b>Old Terms</b>	<b>Meaning</b>
Reference mark	Reference station Reference point	A point with known coordinates, used as the site of a stationary receiver.
Survey mark	Survey station Survey point	A point whose coordinates are to be determined by a survey.
Mark	Station Point	A reference mark and/or survey mark.
Base station	Reference receiver Reference station	A receiver that occupies a reference mark throughout a survey, together with its antenna and any other equipment; or, the site where the equipment is set up.
Rover	Survey receiver Differential station	A receiver that occupies one or more survey marks in the course of a survey, together with its antenna and any other equipment.
Station	—	A base station and/or rover.

## 1.2 Applications and Procedures

An *application* is a type of task that GPS receivers can be used to accomplish. A *procedure* is a well-defined series of steps for accomplishing such a task. For example:

- Control surveying is an application. Static surveying and FastStatic surveying are two procedures that can be used to perform it.
- Topographic surveying is an application. Kinematic surveying is a procedure that can be used to perform it.



The next several sections describe the applications that Series 4000 receivers can serve, and discuss the procedures that are appropriate to each one. Table 1-2 summarizes the applications and procedures. Table 1-3 describes the procedures in more detail. Table 1-4 shows which Series 4000 receivers are recommended each procedure; Table 1-5 shows which antennas are recommended.

**Table 1-2. Series 4000 Applications and Procedures**

Control surveying						
Topographic surveying						
Stakeout						
Precision positioning						
GIS data acquisition						
Navigation						
<b>Procedure</b>						
<b>X</b>						Static surveying (quickstart or preplanned)
<b>X</b>						FastStatic surveying
X	<b>X</b>				<b>X</b>	Kinematic surveying
X	<b>X</b>	<b>X</b>	<b>X</b>	<b>X</b>	<b>X</b>	RTK (Real-Time Kinematic) surveying
		<b>X</b>	<b>X</b>	<b>X</b>	<b>X</b>	Differential GPS
				<b>X</b>	<b>X</b>	Autonomous operation
<b>X</b>	- A primary application for this procedure.					
X	- An auxiliary application for this procedure (may require optional features).					

**Table 1-3. Characteristics of GPS Procedures**

<b>Procedure</b>	<b>Minimum No. of SVs</b>	<b>Minimum Observation Time</b>	<b>Typical Precision</b>	<b>Other Characteristics</b>
Static	4	1 hour	Single-frequency: 20 mm + 2 pp Dual-frequency: 5 mm + 1 pp	Best precision typically on baselines of $\leq 15$ km with single-frequency receiver, and no limit with dual-frequency receiver.
FastStatic	4	5--30 minutes	1 cm + 1 ppm	
Kinematic	4	2 epoch minimum; 2 minutes recommended	2 cm + 2 ppm	Baseline limit is about 15 km. Rover must be reinitialized if it loses satellite lock at any time.
RTK (Real-Time Kinematic)	4	Position fix takes 2 epochs	2 cm + 2 ppm	Baseline limit is about 10 km. Requires a radio link and is normally use with a Seismic Controller or Survey Controller. Rover must be reinitialized if it loses satellite lock at any time.
DGPS (Differential GPS)	2D fix: 3 3D fix: 4	Up to 2 fixes/sec.	Maxwell models : <1m RMS horizontal with 5 SVs, PDOP<4. Other models: 1--3m in same conditions.	Requires a radio link; a Seismic Controller or Survey Controller is optional. Extended navigation features require the Navigation Package Option.
Autonomous operation	1D fix: 2 2D fix: 3 3D fix: 4	Up to 2 fixes/sec.	$\cong 10$ 0m horizontal RMS if Selective Availability is active; $\cong 10$ --2 0m if not.	Requires only one receiver.

### 1.2.1 Control Surveying

A control survey determines the coordinates of selected reference marks in a region of interest. Control surveys must produce very precise coordinates, and so use procedures that may be time-consuming and expensive.

The procedures customarily used for control surveys are *static surveying* and *FastStatic surveying*. Each procedure requires one or more receivers located at marks with known coordinates, and one or more other receivers located at marks whose baselines are to be determined. The receivers must make simultaneous observations of a specified minimum number of satellites for a specified minimum time. The baseline from the reference mark to each unknown mark may then be determined by postprocessing the observed data, using Trimble's GPSurvey software on a personal computer.

Static surveying is the most precise surveying procedure, and the slowest. It requires observations of at least four satellites for a period of 30 to 60 minutes. It yields baselines that are precise to better than  $\pm 5 \text{ mm} + 1 \text{ ppm}$

There are two types of static surveys: single- and dual-frequency. Single-frequency static surveys are appropriate for surveys with baselines shorter than about 15 km under good atmospheric conditions. Dual-frequency static surveys are required to ensure accurate results in geodetic control surveys. Such receivers are used with baselines from 15 km up to about 80 km under good conditions.

FastStatic surveying is a less precise procedure, but is substantially faster. It requires simultaneous observations of at least four satellites for a period of 5 to 20 minutes. It yields baseline components that are precise to better than  $\pm 1 \text{ cm} + 1 \text{ ppm}$ . Because of the relatively short observation time, a single mobile receiver customarily is used to make observations at several unknown marks in the course of a survey.

FastStatic surveying is limited to operations with baselines of about 20 km or less, and it is more sensitive to cycleslips and high PDOP than static surveying is.

### 1.2.2 Topographic Surveying

A topographic survey determines the coordinates of all significant points in a region of interest. The term *topographic* comes from this application's most common use, the preparation of maps. Because of the large number of points that must be surveyed, it uses procedures that emphasize efficiency rather than precision.

The procedure most often used for making topographic surveys is *kinematic surveying*. It utilizes one or more base station receivers that remain at known reference marks, while one or more rovers move about.

The base station and rover receivers must maintain satellite lock continuously throughout the survey. If either receiver loses lock, even momentarily, you must perform a reinitialization procedure before you can go on.

There are two types of kinematic survey: *stop-and-go*, in which the rover must be stationary during an observation, and *continuous*, in which the rover is in constant motion.

The stop-and-go survey is the type customarily used for topographic surveying. It requires an observation of at least two epochs; a minimum two-minute observation is recommended for best precision.

The continuous kinematic survey is useful for aerial and marine surveying applications, and for non-surveying applications such as monitoring the path of a vehicle. It determines a baseline for every epoch in which the receiver is tracking at least four SVs.

Both types of kinematic survey typically are used over ranges of up to about 15 km. Both are precise to about  $\pm 2\text{ cm} + 2\text{ ppm}$ .

RTK (Real-Time Kinematic) surveying is also used for topographic surveying applications. RTK is described in the Stakeout section that follows.

### 1.2.3 Stakeout

When you stake out a site, you locate the points that occupy specified sets of design coordinates. You then can mark those points for future reference, typically by driving stakes into the ground. In some nations this application is called “setting out,” from the process of setting out a group of stakes or other markers.

Stakeout is typically done to prepare a site for a construction or engineering project, or to mark the boundaries of a subdivision.

The most efficient procedure for stakeout applications is *RTK* (Real-Time Kinematic) surveying. RTK is very similar to kinematic surveying except that it uses a radio link between the base station and the rovers, enabling the rovers to display survey results in real time. It comes in the same two varieties as kinematic surveying, stop-and-go and continuous, with the same range and precision. The occupation time required to get a position fix in stop-and-go RTK surveying is the same as for kinematic surveying.



---

**Note** – A Seismic Controller or Survey Controller is required equipment for RTK surveying. The RTK surveying procedure is described in the Survey Controller Operation Manual. This manual does not describe RTK in detail.

---

For stakeout applications with lower precision requirements, *differential GPS* (DGPS) may be used. DGPS is precise to better than  $\pm 1$  meter if Maxwell-based receivers are used, and to  $\pm 2$ --5 meters if not, depending on conditions. It can operate, with gradually decreasing precision, over ranges of up to a few hundred miles. In practice its range usually is limited by the radio link used to connect the base station and rover.

### 1.2.4 Precision Positioning

In a precision positioning application a receiver computes position fixes continuously, in real time. The position fixes may be used to ensure that an object such as a marine oil exploration platform remains in position, or that a vehicle such as a crop dusting aircraft follows its intended course. The receiver may be connected to servomechanisms or graphic displays to assist its control functions.

The procedure customarily used for precision positioning is differential GPS.

### 1.2.5 Navigation

In navigation applications a receiver provides information about a vehicle's location and course, helping the operator to guide the vehicle to its destination. Navigation may be done on water or land, or in the air.

Series 4000 receivers can navigate with whatever real-time positioning technique is enabled: differential GPS, RTK, or autonomous operation. (In *autonomous operation*, a single receiver computes position fixes from whatever satellite signals are available. Precision typically is 100meters horizontal RMS when Selective Availability is in effect, and a few meters when it is not.)

### 1.2.6 GIS Data Acquisition

In this type of application, a receiver collects data for a geographic information system (GIS) database. The application is similar to topographic surveying, except that the receiver must collect text information about survey marks (such as identification numbers or street names) as well as coordinates.

**Table 1-4. Series 4000 Procedures and Receivers**

Static surveying for geodetic control							
Static surveying for local control							Receiver Model
FastStatic surveying							
Kinematic surveying					Differential GPS	GIS data acquisition	Autonomous operation (stand-alone positioning)
RTK surveying							
X	X	X	X	X	X	X	4000SSE Land Surveyor IID
X	X	X		X	X	X	4000SSE Geodetic Surveyor & Geodetic System Surveyor
X	X	X		X	X	X	4000SSE Site Surveyor
X	X	X		X	X	X	4000SSi Site Surveyor
X	X	X		X	X	X	4000SSi Geodetic Surveyor
X	X	X		X	X	X	4000SSi Geodetic System Surveyor
X	X		X	X	X	X	4000SE Land Surveyor†
X	X	X	X	X	X	X	4000SE Land SurveyorII & System SurveyorII
X	X		X	X	X	X	4000SE System Surveyor†
X	X		X		X	X	4000RS or 4000RSR Reference Surveyor
X	X		X		X	X	4000DS or 4000DSR Differential Surveyor
X	X		X	X		X	GIS Surveyor Receiver
X	- A primary procedure for this unit.						
X	- An auxiliary procedure for this unit (receiver may require optional features).						
†	- This unit is no longer in production.						

**Table 1-5. Series 4000 Procedures and Antennas**

Static surveying for geodetic control							
Static surveying for local control							
FastStatic surveying							
Kinematic surveying							
RTK surveying							
Differential GPS							
GIS data acquisition							
Autonomous operation (stand-alone positioning)							
<b>Antenna Model</b>							
	X		X	X	X	X	Compact Dome Antenna‡
	X		X	X	X	X	Modular Antenna
	X	X			X	X	Compact L1 Antenna‡
	X				X	X	L1 Geodetic Antenna†
	X		X		X	X	4000ST and SST Kinematic External Antenna†
X	X	X			X		Compact L1/L2 Antenna without groundplane
X	X	X			X		L1/L2 Kinematic Antenna†
X	X	X			X		Compact L1/L2 Antenna with groundplane
X	X	X			X		Permanent Reference Station L1/L2 Geodetic Antenna
X	X	X			X		L1/L2 Geodetic Antenna†
<p><b>X</b> - A primary procedure for this unit.</p> <p><b>X</b> - An auxiliary procedure for this unit.</p> <p><b>†</b> - This unit is no longer in production.</p> <p><b>‡</b> - For GIS data acquisition, the Compact Dome Antenna is recommended for rovers; the Compact L1 Antenna is recommended for base stations.</p>							



### 1.3 How to Use Your Receiver's Manuals

Each Series 4000 receiver is accompanied by several manuals:

- The *Series 4000 Application Guide* (this manual) discusses the capabilities and limitations of the procedures you can perform with a Series 4000 receiver, and explains how to perform them. When you go into the field, take this manual with you for reference.
- Each *Series 4000* receiver Series 4000 has its own *User Guide*. For example, the *4000SSE User Guide* describes the 4000SSE Geodetic Surveyor and the 4000SSE Geodetic System Surveyor. A *User Guide* discusses characteristics of a receiver that are not shared by all models of the Series 4000. It also explains how to unpack and check out a receiver, and presents an introductory guide to its use. It contains tables that describe options, accessories, and spare parts applicable to your receiver.
- The *Series 4000 Receiver Reference* describes all features found in Series 4000 receivers, in complete detail. It will be useful when you need to know exactly how a particular key or data display works, or you need technical information about a receiver's power requirements, inputs, or outputs.
- Near the back of the *Series 4000 Receiver Reference* are a Glossary that defines many terms and abbreviations used in these manuals, and a Bibliography of other literature of interest to users of Series 4000 receivers.
- The *Series 4000 Quick References* summarize the procedures most often performed with Series 4000 receivers. They are much less detailed than the *Series 4000 Application Guide*, but their compact format makes them very convenient to carry in your shirt pocket or backpack.

## 1.4 Additional Sources of Informatio

Several agencies maintain free sources of information about the status of the NAVSTAR Global Positioning System. This information includes descriptions of known problems, plans for testing and maintenance, etc.

If you have a modem, check Trimble's Customer Support Bulletin Board Service (BBS) on a regular basis for application notes, new software release notices, and other information. Refer to the Preface to this manual for additional information on the Customer Support BBS.

The Trimble Assistance Center (TAC) may also be called if you have problems and cannot find the information you need in this document. Refer to the Preface to this manual for additional information on contacting the TAC.

United States Coast Guard's GPS Information Center (GPSIC) has the following services:

Recorded voice message	703-313-5907
Live watch (8 AM to 4 PM Eastern Time). The watch can give some technical assistance with the BBS, and can relay reasonable amounts of BBS information to callers who are not equipped to dial into a BBS.	703-313-5900
Fax communications	703-313-5920
General BBS number: 8 data bits, no parity 1 stop bit, up to 9600 baud	703-313-5910
Alternate BBS numbers in case of trouble with 5910.	703-313-5918 703-313-5919
BBS number for high-speed US Robotics modems	703-313-5917

The United States Air Force's Space Systems Division operates a BBS out of Holoman Air Force Base. (This BBS was formerly operated out of Yuma, AZ, and is often known as "the Yuma BBS.")

General BBS number at Holoman AFB: 505-679-1525  
8 data bits, no parity, 1 stop bit, up to 9600 baud



## 2 Static Surveying

---

Static surveying is the most precise surveying procedure a Series 4000 receiver can perform, and also the slowest. It requires observations of at least four satellites for a period of about 60 minutes.

There are two types of static surveys: single- and dual-frequency. Single-frequency static surveys are appropriate for surveys with baselines shorter than about 15 km under good atmospheric conditions. They yield baselines that are precise to better than  $\pm 2 \text{ cm} + 2 \text{ ppm}$ . Dual-frequency static surveys are required to ensure accurate results in geodetic control surveys, with baselines up to 30 km or more under good conditions. They yield baselines that are precise to better than  $\pm 5 \text{ mm} + 1 \text{ ppm}$ .

The occupation time required for a static survey depends on many factors. Until you develop substantial experience with the procedure, it is wise to err on the side of safety. Trimble recommends an occupation time of at least 45 minutes during times when five or more satellites are available, or 60 minutes during times when only four satellites are available. Trimble's Plan or Quick Plan program can help you determine satellite availability at a specified site and time.

The following sections discuss static surveying topics in this order:

1. Equipment and software required.
2. Setting up the equipment in the field.
3. Other applications of the static surveying procedure.

4. How to run a quickstart static survey (a type of static survey that requires minimal advance planning).
5. How to define and run a preplanned static survey.
6. How to use the auto-survey timer to run one or more surveys.
7. How to check the status of a survey.

*A Field Guidebook for Static Surveying* provides another description of static surveying procedures, with emphasis on survey design and planning. A full citation is given in the bibliography of the *Series 4000 Receiver Reference*.

## 2.1 Equipment and Software Require

A static survey requires at least two receivers, each with an antenna, tripod, and tribrach. For a dual-frequency static survey, you must use dual-frequency receivers and antennas.

The preferred antenna is the Compact L1 Antenna with groundplane, or the Compact L1/L2 Antenna with groundplane. The latter antenna is required for dual-frequency work. The earlier L1 Geodetic Antenna or L1/L2 Geodetic Antenna may also be used.

If multipath effects are not a concern, the Compact Dome Antenna may be used for single-frequency work, and the Compact L1/L2 Antenna without groundplane may be used for dual-frequency work.

The L1/L2 Geodetic Antenna may be used for single- or dual-frequency work; it is a predecessor of the Compact L1/L2 Antenna.

The Permanent Reference Station L1/L2 Geodetic Antenna may be used in place of the Compact L1/L2 Antenna; it is electrically identical but has a fixed groundplane.

The recommended software packages for postprocessing static survey results are GPSurvey (a Microsoft Windows application) and TRIMVEC Plus (a DOS application).

## 2.2 Setting Up the Equipment

**Base station receivers and rovers.** You must set up one or more base stations, also called reference receivers, at reference marks whose WGS-84 or NAD-83 coordinates are known with sufficient accuracy for your purposes.

You must set up one or more rovers, or survey receivers, at the survey marks whose coordinates are to be determined. (All Series 4 000 surveying procedures use the term rover for a receiver that is used to find the coordinates of a survey mark.)

The hardware and setup procedures for base stations and rovers are the same.

To set up a receiver:

1. Set up an antenna on a tripod with tribrach; center and level the antenna and measure its height. The correct procedure is described in the section *Using and Caring for an Antenna*.
2. Turn the receiver on. Wait for it to complete its self-test and display the *Log Data* menu, which look something like this:

```
QUICK-START NOW! (SINGLE SURVEY)  --  
START PRE-PLANNED (SINGLE SURVEY)  --  
START FAST STATIC OR KINEMATIC SURVEY  --  
                                         MORE  --
```

If the receiver displays a screen similar to the one below, the last survey it ran was never completed. See the section *Restarting a Session After a Power Failure*.

```
SURVEY RESTARTED  
  
AFTER POWER FAIL  
** PRESS ANY KEY **
```

## 2.3 Other Applications of Static Surveying

The static surveying procedure is useful in several contexts other than control surveying.

Many non-surveying applications involve logging satellite measurement data, and the data logging procedure is identical to the static surveying procedure. For example, this procedure can be used to log position fixes in differential GPS operations.



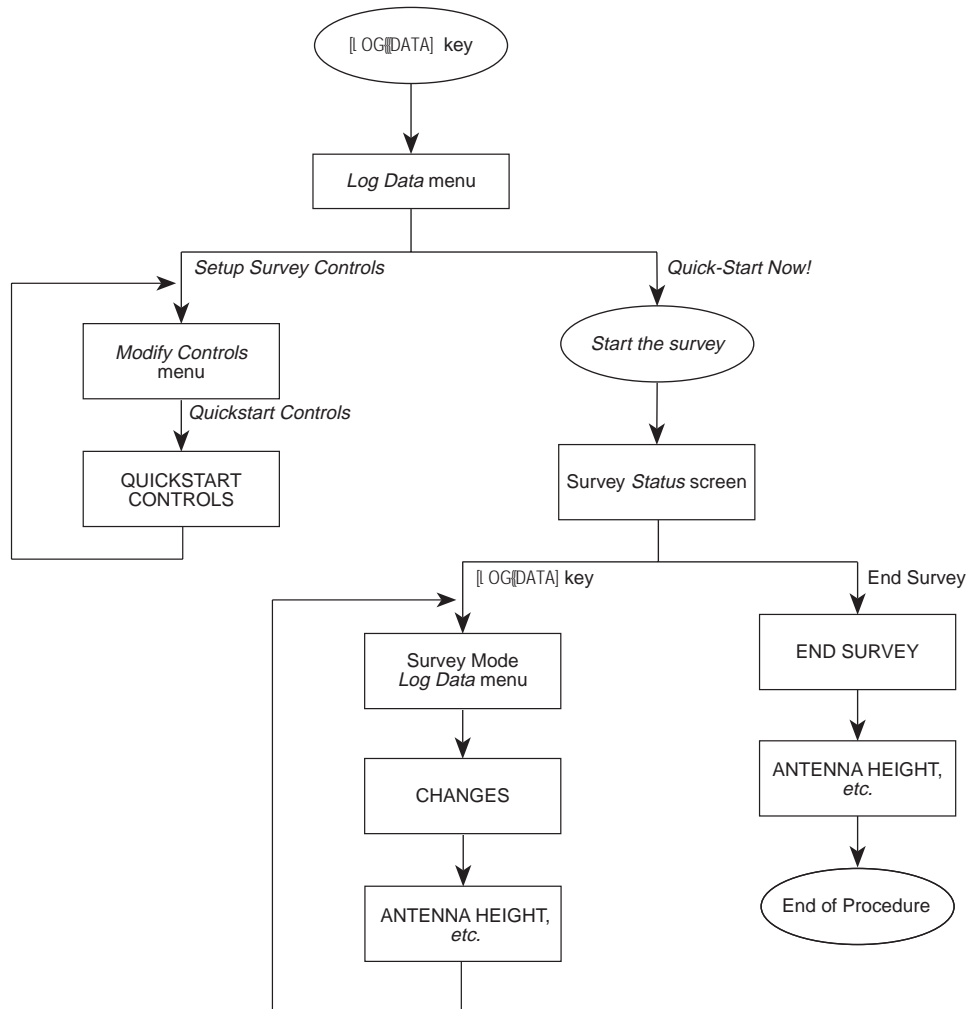

**Figure 2-1. Quickstart Static Survey Procedure**

### 2.3.1 Running a Quickstart Survey

A quickstart survey is “quick” in the sense that you can start it without defining a station and schedule a session first, and without setting many of the parameters that a preplanned survey requires.

A quickstart session requires less preparation than a preplanned session, but it requires a person to stay near the receiver to start and stop data logging. Thus, if you are working alone, you can quickstart just one receiver. If you are working with a team, you can quickstart as many receivers as there are people to attend them.

#### How to Inspect or Modify the Quickstart Controls

The recommended values for the quickstart control parameters are all default values, shown in the screen below. Thus, it is usually not necessary to change these parameters' values. If you should need to change the values, or verify that they are set correctly:

1. Select SETUP SURVEY CONTROLS from the *Log Data* menu.
2. If the receiver displays this screen, select MODIFY QUICKSTART CONTROLS.

```
MODIFY QUICKSTART CONTROLS --
MODIFY FAST STATIC CONTROLS --
MODIFY KINEMATIC CONTROLS --
```

3. The receiver displays this screen:

```
QUICKSTART CONTROLS |
STORE POSITION:  NORMALLY |CHANGE
ELEVATION MASK:+15' MIN SVs: 03 |MINUS
MEAS SYNC TIME: 015.0 SEC |ACCEPT
```

Set each parameter to an appropriate value.

- STORE POSITION: This parameter has the same set of possible values as the POSITION LOGGED parameter in the SPECIAL CONTROLS screen in the procedure for defining a preplanned session. For more information, see the section Step 4: Set Special Controls.
- ELEVATION MAS : The elevation below which satellites will not be used for data logging. For more information, see the section Step 6: Set Additional Parameters.
- MIN SVs: The minimum number of satellites that must be tracked for data logging to take place. For more information, see the section Step 6: Set Additional Parameters.
- MEAS SYNC TIME: The interval at which the receiver will log data. For more information, see the section Step 6: Set Additional Parameters.



---

**Note** – These parameters should have the same values on all receivers used in a survey. If you must change them during a survey, change them on all receivers at the same time.

During a survey, ELEVATION MASK and MEAS SYNC TIME may be changed from the Control menu's MASKS/SYNC TIME selection. STORE POSITION and MIN SVs: cannot be changed.

Operating parameters that are not on this screen should never be changed during a session.

---

## How to Start a Quickstart Session

To start a quickstart session:

1. To ensure that the receiver performs the survey in a known, correct state, set the power-up parameters to their default values. Select DEFAULT CONTROLS from the *Control* menu to display this screen:

```
INITIALIZE ALL CONTROLS TO DEFAULT |
SETTINGS AND RESTART RECEIVER     |
                                   | NO
                                   | YES
ARE YOU SURE ?                    |
```

Press the YES softkey and wait for the receiver to reset itself.

2. If you are performing a dual-frequency survey, confirm that the receiver is configured for dual-frequency operation. See the section *Configuring Single or Dual-Frequency Operation* in Appendix A for details.
3. Select SETUP SURVEY CONTROLS from the *Log Data* menu. If the receiver displays a menu of types of controls, select MODIFY QUICKSTART CONTROLS to display this screen:

```
QUICKSTART CONTROLS                |
STORE POSITION:  NORMALLY            |CHANGE
ELEVATION MASK:+15°  MIN SVs: 03  |MINUS
MEAS SYNC TIME: 015.0 SEC          |ACCEPT
```

Set the parameters to appropriate values. The values shown above are recommended for all standard applications.

4. Select QUICK-STARTNOW! from the *Log Data* menu.
5. When the required number of satellites become available above the elevation mask, the receiver starts logging data.

When you start a quickstart survey, the receiver creates a default data file name based on the receiver serial number and today's date. (See the sections *How the Receiver and Programs Handle File Names* and *Renaming the Current Data File* in Appendix A.) The reference position is taken from the most recent position fix. Positioning mode is forced to Auto 3D/2D.

**Antenna parameters.** You may enter values for the antenna parameters at any time during a survey, as explained in the section *Entering Antenna Parameters* in Appendix A. If you do not do so, the receiver will prompt you for them at the end of the survey. If you do not enter them then, you must do so when you postprocess the logged data.

### Importance of Simultaneous Observations

Because the static surveying procedure is intended for control surveying, where precision is essential, it is customary to make simultaneous observations with all of the receivers used in a given survey. This enables the postprocessing software to compute a baseline between every pair of receivers, not just between the base station and each rover. The additional baselines may then be cross-checked for consistency, increasing the precision and reliability of the results. This type of survey is called a *network* survey, as opposed to a *radial-arm* survey in which baselines are computed only between each rover and the base station.

### How to End a Quickstart Session

1. Press the [LOG/DATA] key to display this screen:

```
SURVEY:                                |USER INPUT  
                                           |  CHANGES  
                                           |  
                                           |END SURVEY
```

2. Press the END SURVEY softkey to display this screen:

```
STOP THE CURRENT SURVEY ?      | YES
                                |
                                |
                                | NO
```

3. Select YES. The receiver stops logging data.

If you have already entered values for the antenna parameters, the receiver returns directly to the *Status* screen in positioning mode. This ends the quickstart static surveying procedure.

If you have not yet entered antenna parameters, the receiver goes on to the next step.

4. The receiver briefly displays the following screen, then the antenna parameter screen.

```
SURVEY ENDED -- GET READY TO INPUT
                    ANTENNA HEIGHT
```

5. Enter appropriate values for the antenna parameters, as explained in “Entering Antenna Parameters” on page 193. When you are done, the receiver returns to the *Status* screen in positioning mode.

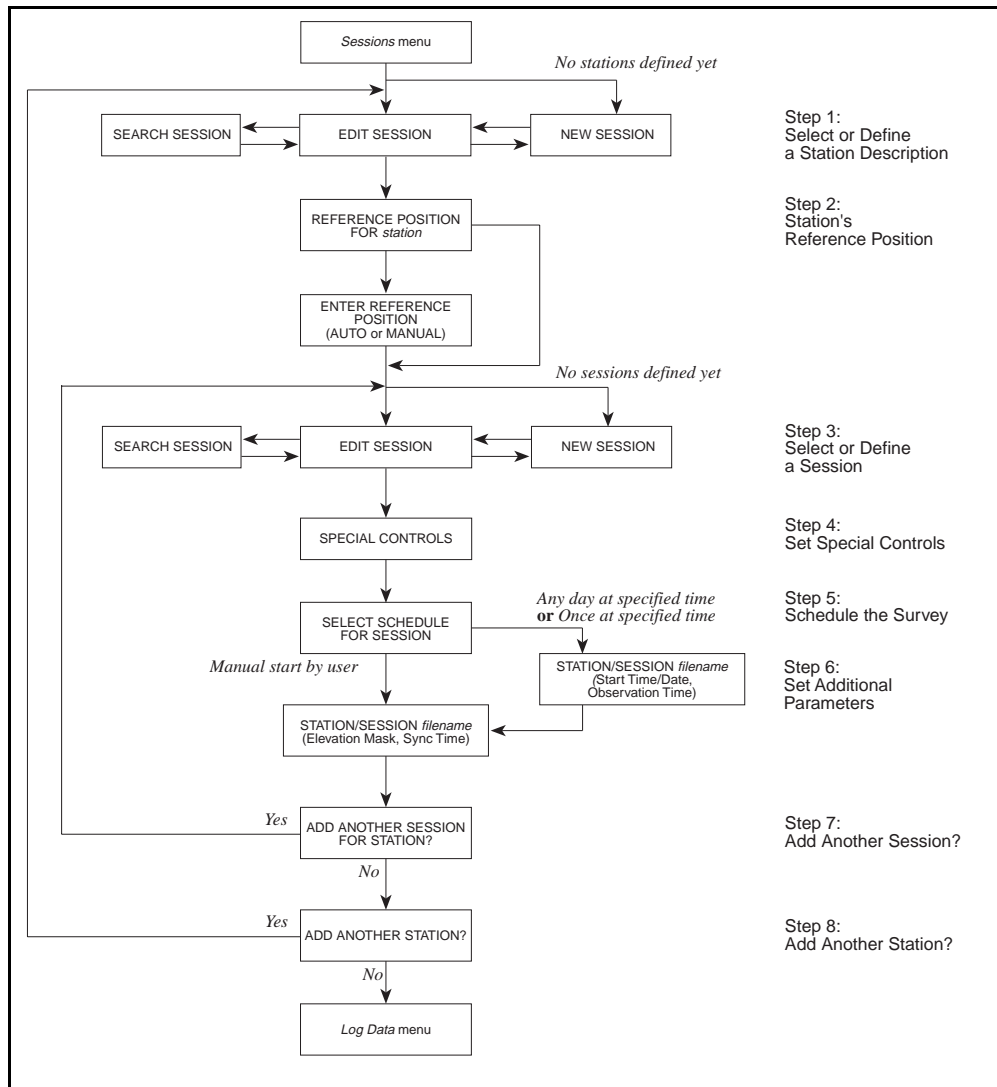

**Figure 2-2. Sessions Process**

### 2.3.2 Defining a Preplanned Static Survey

A *preplanned static survey* must be scheduled before it is run. By scheduling a preplanned survey, you can ensure that every receiver will start and stop logging data simultaneously, at the intended times. You can also leave a receiver to run unattended, enabling one or two people to collect data simultaneously at several sites.

Note that quickstart and preplanned surveying sessions are just two different methods of *starting and stopping* a static survey. In a single surveying session you may run quickstart sessions on some receivers and preplanned sessions on others.

To schedule a receiver for a preplanned session, you must:

1. Press the [SESSIONS] key to begin the *Sessions* process. Select or define a *station*—a mark that the receiver will occupy while logging data.
2. Enter the coordinates of the station.
3. Select or define a description of a *session*—a period of data logging.
4. Set the data logging parameters (special controls) to use for the session.
5. Specify the session's start time and duration.
6. Set the additional parameters (elevation mask, etc.) to use for the session.
7. Set up the receiver in the field before the time when the session is scheduled to start.



---

**Note** – The *Sessions* screens have an inherent order, which defines the *Sessions* process. (See Figure 2-1.) In general, pressing the [ENTER] key takes you forward one step in the procedure; pressing the [CLEAR] key takes you back one step.

---



### Step 1: Select or Define a Station Description

Each station description (each mark) consists of:

- A numeric *index* from 1 to 30 which uniquely identifies the station in the receiver's memory.
- A four-character *station ID*, chosen by you. You must refer to a station description's station ID when you define a session description.
- A name of up to three lines, chosen by you. The name identifies the station in postprocessor screens and reports.

To define a new station description:

1. Press the [SESSIONS] key.

If no station descriptions are defined in the receiver's memory, the receiver displays this screen:

```

NEW STATION:  0000      |  ALPHA
                  |
                  |  ACCEPT
  
```

If any station descriptions are defined, the receiver displays this screen:

```

EDIT STATION:  1111  ID:01 |NEXT STATION
NAME:          |PREV STATION
                  |  NEW STATION
                  |  DELETE IT
  
```

2. If the EDIT STATION screen is displayed, press the NEW STATION softkey to display the NEW STATION screen.
3. Enter the station's ID. Press the [ENTER] key or the ACCEPT softkey to move the cursor to the NAME field.

4. Enter a name for the station description, up to three lines long. You may press the ALPHA key to shift the keypad into alphanumeric mode. Then press [ENTER] again and go on to the next step in the *Sessions* process.

To select an existing station:

1. Press the [SESSIONS] key. The receiver displays the EDIT STATION screen, shown above.

The first line shows one station's four-digit station ID and two-digit index.

2. Press the NEXT STATION and PREV STATION softkeys until the screen shows the station you want to select.

You may also search for a station description by entering its ID in the first field. When you start entering the ID, a separate SEARCH screen appears. When you are done entering the ID, press [ENTER] or ACCEPT. The receiver will search for the station description, and will display it in the EDIT STATION screen if found.

3. You may change the station's name, if appropriate. Press [ENTER] to accept the change, if any, and go on to the next step in the *Sessions* process.



---

**Note** – You should also delete old station descriptions to make room for new ones. To delete a station description, display that description as if you were going to select it; then press the DELETE IT softkey.

---

## Step 2: Enter the Station's Reference Position

The *reference position* gives the accepted coordinates of the antenna's location during the survey.

1. When you leave step 1 of the *Sessions* process, the receiver displays this screen:

```
REFERENCE POSITION FOR: 1234
                        AUTOMATIC <*
                        MANUAL  --
```

The first line displays the ID of the station you selected.

2. Select AUTOMATIC, or press [ENTER]. This directs the receiver to set the reference position by taking a position fix at the start of the survey. Go on to step 3.

Note that the position fix is only needed to get the static survey started. Its low precision will not limit the precision of the survey's results.

### Step 3: Select or Define a Session Description

Each session description has:

- A session ID, which must be unique among sessions stored in the receiver's memory.

A session ID normally consists of the session's UTC day of year followed by a sequence number. For example, the first session conducted on February 1, UTC time, would customarily be named 032-1 (because February 1 is the 32nd day of the year); the second session on that date would be 032-2; and so on.

You can see the UTC day of year by pressing [STATUS], then selecting DATE.

- A reference to a station description.
- A group of parameters called *special controls* which affect the way data logging is done.

- A group of *antenna parameters* which describe the antenna to be used for the survey.
- The session's start time and duration.

To define a new session:

1. If no sessions are defined in the receiver's memory, the receiver displays this screen:

```
NEW SESSION:  000-0      | ALPHA
STATION: 1234          |
NAME:                |
                       | ACCEPT
```

If any sessions are defined, the receiver displays this screen:

```
EDIT SESSION:  000-0      |NEXT SESSION
STATION: 1234          |PREV SESSION
NAME: TNL             | NEW SESSION
                       |  DELETE IT
```

2. If the EDIT SESSION screen is displayed, press the NEW SESSION softkey to display the NEW SESSION screen.

3. Enter a session ID and press the [ENTER] key or the ACCEPT softkey. Go on to step 4 of the *Sessions* process.

To select an existing session:

1. Press the NEXT SESSION and PREV SESSION softkeys until the screen shows the session you want to select.

You may also search for a session description by entering its ID in the first field. When you start entering the ID, a separate SEARCH screen appears. When you are done entering the ID, press [ENTER]. The receiver will search for and the session description, and will display it in the EDIT SESSION screen if found.



---

**Note** – You should delete old session descriptions to make room for new ones, just as you can delete old station descriptions. To delete a session description, display that description as if you were going to select it; then press the DELETE IT softkey.

---

#### Step 4: Set Special Controls

The *special controls* are a group of parameters that affect the way the receiver logs data when running a preplanned survey with this session description. You set a session's special controls each time you select the session, not when you create it.

To set the special controls:

1. The receiver displays this screen:

```
SESSION 123-1 SPECIAL CONTROLS
                USE SPECIAL CONTROLS  --
                USE RECEIVER DEFAULTS  <*
```

2. To use the special controls' default values, press the USE RECEIVER DEFAULTS softkey. This is appropriate in most cases.

If you need to set any of the special controls to other values, press the USE SPECIAL CONTROLS softkey. The receiver displays this screen:

```
SESSION 123-1 SPECIAL CONTROLS
POSITION LOGGED [  NORMALLY  ] <- CHANGE
OVER DETERMINE [   ENABLE   ] <- CHANGE
LOG SMOOTH PR  [  DISABLE   ] <- CHANGE
POSITION TYPE  [   3D/2D    ] <- CHANGE
HEIGHT SOURCE  [    AUTO    ] <- CHANGE
```

POSITION LOGGED controls the type of data that is logged and frequency of logging. Possible values are:

- NORMALLY: Log satellite data once per epoch, and a position fix once every five minutes. This is appropriate for most baseline surveying applications.
- EVERY CYCLE: Log satellite data and a position fix once per epoch. This is appropriate for applications that require both satellite data and real-time position fixes.
- EXCLUSIVELY: Do not log satellite data. Log a position once per epoch. This is appropriate for some types of applications that require real-time position fixes only.

LOG SMOOTH PR: Controls logging of smoothed pseudoranges. For static surveying this option must be set to its default value, DISABLED.

OVER DETERMINE, POSITION TYPE, and HEIGHT SOURCE concern position fixes only. They thus have no effect on static surveys, although they may affect other applications that use the same procedure.

3. When all of the parameters are set, press [ENTER] to display the next screen. Go on to step 5.

### Step 5: Schedule the Session

Next you must specify when the survey will start and stop.

1. The receiver displays this screen:

```

SELECT SCHEDULE FOR: 1234-043-1
                    MANUAL START BY USER < *
                    ANY DAY AT SPECIFIED TIME --
                    ONCE AT SPECIFIED DATE AND TIME --

```

The first line shows the station number, (in this case, 1234) followed by the session number (043-1).

2. Press a softkey to select the manner in which the session is to be started. For static surveys, the appropriate choice is either MANUAL START BY USER or ONCE AT SPECIFIED TIME.
  - MANUAL START BY USER: The session will be started and stopped by the user. The receiver goes directly to the next step of the *Sessions* process (step 6).
  - ANY DAY AT SPECIFIED TIME: If started with the START PREPLANNE procedure, the session will be run once, at the next occurrence of a specified time of day.

If started with the ENABLE AUTO-SURVEY TIMER procedure, the session will be run *every* day, at the specified time, until the auto-survey timer is disabled.

The procedure for specifying the time is similar to the one described below for ONCE AT SPECIFIED DATE AND TIME, except you are not prompted to enter a date.

- ONCE AT SPECIFIED DATE AND TIME : The session will be run once, at a specified time on a specified day, whether started with START PREPLANNED or ENABLE AUTO-SURVEY TIMER.

When you select this choice, the receiver displays this screen:

```
STATION/SESSION: 1234-044-1
START TIME/DATE: 10:58 AM PST
                  SUN 29-01 (JAN)-95
OBSERVATION TIME: 01:15 (hh:mm)  ACCEPT
```

The screen shows the scheduled start time and date and the observation time. Change the values as appropriate and press the [ENTER] key or the ACCEPT softkey. Go on to step 6 of the *Sessions* process.

### Step 6: Set Additional Parameters

Next you must review the additional parameters, and change their values if appropriate.

1. The receiver displays this screen:

```
STATION/SESSION: 1234-043-1      |
RECEIVER DEFAULTS IN USE        |
ELEVATION MASK:+15' MIN SVs: 03 | MINUS
MEAS SYNC TIME: 015.0 SEC       |ACCEPT
```

The second line says RECEIVER DEFAULTS IN USE if all of the special controls have their default values, or SPECIAL CONTROLS IN USE if any of them have been changed.



The third and fourth lines display this session's values for the additional parameters: elevation mask, minimum number of SVs required to log data, and sync time (the interval at which the receiver will log data). The cursor is initially in the ELEVATION MASK field.

2. ELEVATION MASK is the elevation below which satellites will not be used for data logging.

A mask of  $+15^\circ$  is appropriate in most situations. You may want to set a higher or lower mask if the horizon is unusually obstructed or clear. Never set the mask to a value below  $10^\circ$ , since atmospheric disturbances will impair the quality of the results even if the horizon is perfectly clear.

Press [ENTER] or ACCEPT to go on to the next field.

3. MIN SVs is the minimum number of satellites required to make observations. Static surveying requires 4 satellites, but MIN SVs ordinarily should be set to 3 to ensure that the receiver will continue logging data if the number of available satellites temporarily drops below 4. Press [ENTER] or ACCEPT again.
4. MEAS SYNC TIME is the rate at which the receiver will take measurements. A value of 1.5 seconds is appropriate for all standard operations. Press [ENTER] or ACCEPT again.
5. Go on to the next step of the *Sessions* process (step 7).

### Step 7: Add Another Session

Next the receiver asks if you want to select and schedule another session for the same station:

```
ADD ANOTHER SESSION FOR      | YES
   STATION: 1234 ?           |
                               |
** 47 SESSIONS FREE **      | NO
```

To schedule another session, press the YES softkey. Return to step 3.

If you do not want to schedule another session, press the NO softkey.  
Go on to step 8 .

### Step 8: Add Another Station

Next the receiver asks if you want to select and schedule sessions for another station:

```
ADD ANOTHER STATION ?      | YES
                             |
** 27 STATIONS FREE **    |
** 47 SESSIONS FREE **   | NO
```

To select or define another station, press the YES softkey. Return to step 1.

If you do not want to schedule sessions for another station, press the NO softkey. The receiver displays the *Log Data* menu. This ends the *Sessions* process.



---

**Note** – Although the *Sessions* process leads directly to the *Log Data* menu, it is completely independent of the procedure for running a survey. There are no limitations on the procedures you may perform between the time you define a session and the time you use it to run a survey.

---

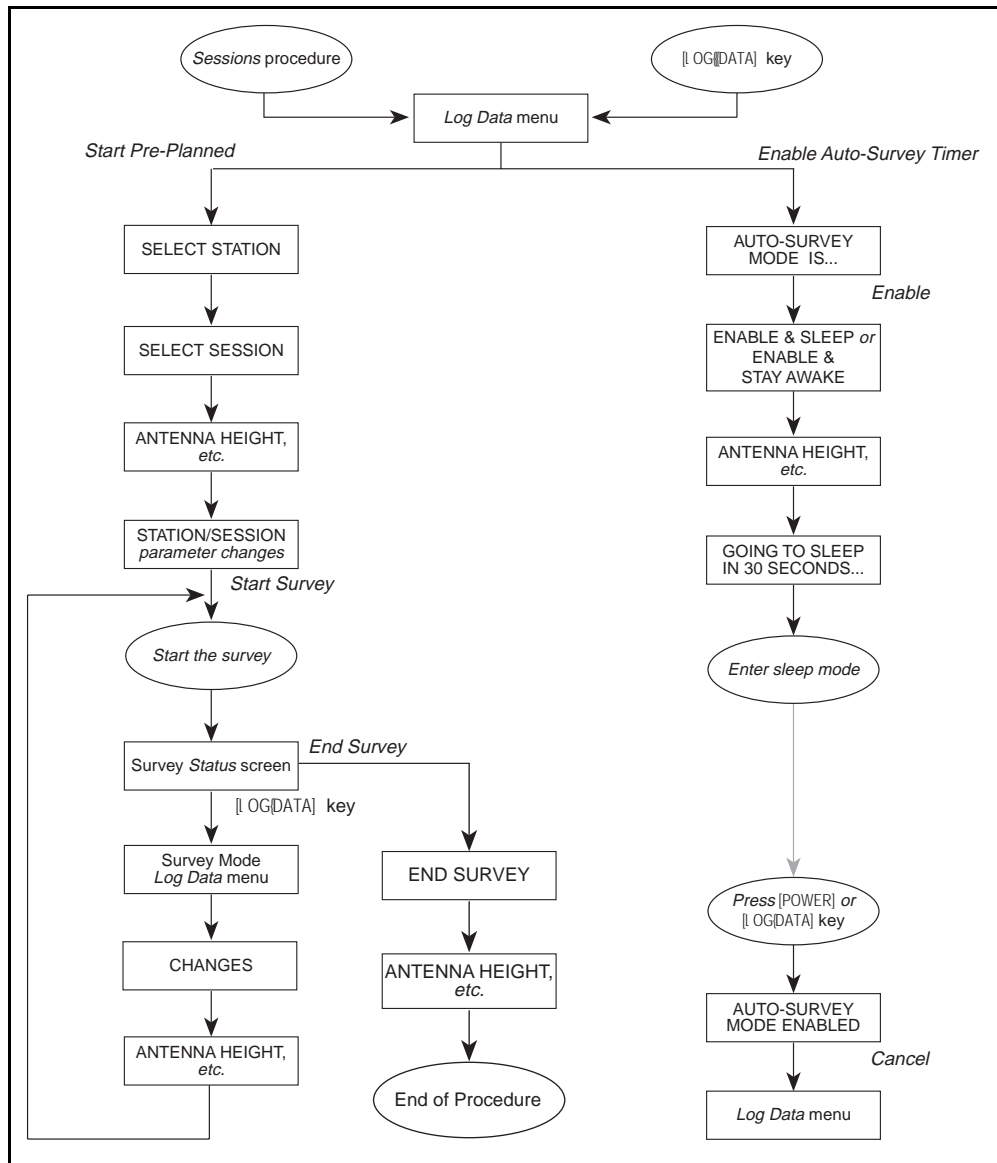

Figure 2-3. Preplanned Static Survey Procedure

### 2.3.3 Running a Preplanned Survey

Once you have set up a station and session description, you are ready to run a preplanned survey.

Set up each receiver as explained in the section Setting Up the Equipment in Chapter 3.

1. To ensure that the receiver performs the survey in a known, correct state, set the power-up parameters to their default values. Select DEFAULT CONTROLS from the *Control* menu to display this screen:

```
INITIALIZE ALL CONTROLS TO DEFAULT |
SETTINGS AND RESTART RECEIVER    |
                                  | NO
                                ARE YOU SURE ? | YES
```

Press YES softkey and wait for the receiver to reset itself.

2. If you are performing a dual-frequency survey, confirm that the receiver is configured for dual-frequency operation. For specifics, see the section Configuring Single or Dual-Frequency Operation in Appendix A.
3. Press [F1] (LOG DATA). The receiver displays the main *Log Data* screen, which will resemble this one:

```
QUICK-START NOW! (SINGLE SURVEY) --
START PRE-PLANNED (SINGLE SURVEY) --
START FAST STATIC OR KINEMATIC SURVEY --
                                  MORE --
```

4. Select START PRE-PLANNED. The receiver displays this screen:

```

SELECT STATION: 1234 ID:02 |NEXT STATION
NAME:                |PREV STATION
                       |
                       |      ACCEPT
  
```

Use the NEXT STATION and PREV STATION softkeys to display the appropriate station description. (You may also enter the station ID from the keypad.) Press [ENTER] or ACCEP .

5. The receiver prompts you to enter antenna parameters by displaying the antenna parameter screen.

To start the survey quickly, just press ACCEPT and go on to the next step. You may set the antenna parameters during the session, or let the receiver prompt you to do so when the session ends.

To set the antenna parameters now, see the section Entering Antenna Parameters in Appendix A

6. Next the receiver displays this screen:

```

STATION/SESSION: 2345-093-1|START SURVEY
APPROX. MEMORY LEFT: 8.4 HR|  USER INPUT
                           |      CHANGES
PWR1+[*****] 2:01:59 PM PST|
  
```

The first line shows the name of the data file that the receiver has created for this session. (You can change the file's name at any time during the session; see the section Renaming the Current Data File in Appendix A.) The second line shows the approximate amount of memory left for logging data, expressed in hours of operation at the current parameter settings.

To start the survey, press START SURVEY.

7. What happens next depends on the starting mode specified by the session description:
  - *Manual Start by User:* The session starts as soon as the required number of satellites is available above the elevation mask.
  - *Any Day at Specified Time:* The receiver will start the session at the next occurrence of the specified time.
  - *Once at Specified Date and Time:* The receiver will start the session at the specified date and time.

If a session's scheduled start time is past but its scheduled duration has not expired, the receiver starts the session immediately and runs it until it would have ended if started on time. For example, if a session is scheduled to start at 1500 hours and run for one hour, and is started at 1545 hours, the session will start immediately and run for 15 minutes.

### 2.3.4 Entering Antenna Information During a Survey

You can enter or correct the antenna information at any time while a survey is running:

1. Press [LOG][DATA] to display the SURVEY screen:

```

SURVEY:                                | USER INPUT
                                           |   CHANGES
                                           |
                                           | END SURVEY
  
```

2. Select CHANGES. The receiver displays this screen:

```

SURVEY CHANGES:                        | ANTENNA HEIGHT
                                           |   FILE NAME
                                           |
                                           |
  
```

3. Select ANTENNA HEIGHT. The receiver displays this screen:

```

ANT HEIGHT: 0000.0000 INCHES           | UNITS
MEAS TYPE:  UNCORRECTED                 | NEXT
ANT TYPE:   EXTERNAL (UNKNOWN)         | NEXT
ANT SERIAL: 000000                     | ACCEPT
  
```

Enter values as explained in the section Running a Preplanned Survey.

When you leave this screen, the receiver returns to the SURVEY CHANGES screen. You may press [CLEAR] to move back up the screen hierarchy, or press [STATUS] to display the main *Status* screen.

### How to Enter Field Notes or Event Marks During a Survey

You can enter field notes and event marks at any time during a survey, as explained in the section Entering Supplementary Data in Appendix A.

### **How to End a Preplanned Survey**

A preplanned session normally ends when its scheduled duration has passed. If necessary, though, you can end a preplanned session at any time. Follow the procedure for ending a quickstart session, described in the section *How to End a Quickstart Session*.

### **2.3.5 Using the Auto-Survey Timer**

The auto-survey timer lets you schedule one or more preplanned static surveying sessions that were defined to start at a specified time. In addition, this feature makes the receiver “go to sleep” until the first session is scheduled to begin. While the receiver is asleep it appears to be turned off, except that the TIMER light flashes several times a minute.

Five minutes before the scheduled start of the first session, the receiver wakes up and begins to acquire SVs. It then starts the session automatically. The receiver may stay awake or go back to sleep between sessions, depending on its parameter settings. After running the last scheduled session, the receiver turns itself off.

The auto-survey timer is useful for unattended base station operation. You can use it to schedule a series of data logging sessions to coincide with times when you are conducting surveys with a rover. By not logging data between sessions, you conserve the base station's memory and increase its effective data logging capacity.

The auto-survey timer also conserves battery power, since battery drain is very low when the receiver is asleep. A fully charged camcorder battery can power a receiver for about 3 .5hours when it is awake, or for more than a week when it is asleep. In fact, you can safely replace a battery while the receiver is asleep without bothering to attach the new one before you remove the old one.



### When Scheduled Sessions Are Run

When you enable the auto-survey timer, you schedule *all* sessions that have been defined to start “Any Day at Specified Time” or “Once at Specified Date and Time.” You cannot select some defined sessions and pass over others.

Sessions defined to start “Any Day at Specified Time” will be run *every day* at the specified time until the auto-survey timer is canceled. Sessions defined to start “Once at Specified Date and Time” will run once, the same as if started with START PREPLANNED.

If a session's scheduled start time is past when you enable the auto-survey timer, but the session's scheduled duration has not expired, the receiver starts the session immediately and runs it until it would have ended if started on schedule. For example, if a session is scheduled to start at 1500 hours and run for one hour, and you enable the auto-survey timer at 1545 hours, the session will start immediately and run for 15 minutes.

When you use the auto-survey timer, take care not to schedule overlapping sessions. Since only one session can run at a time, the later session will not start until the earlier one ends.

### How to Enable the Auto-Survey Timer

To schedule preplanned sessions with the auto-survey timer:

1. Define one or more sessions that are scheduled to begin at specified dates and times.
2. From the *Log Data* menu, select ENABLE AUTO-SURVEY TIMER. The receiver displays this screen:

```
AUTO-SURVEY MODE IS OFF | ENABLE
SCHEDULED SESSIONS:    |
  1 EVERYDAY SESSION   |
NO ONCE-ONLY SESSIONS |
```

The first line shows whether the auto-survey timer is on or off. The other lines show the number of “Any Day at Specified Time” and “Once at Specified Date and Time” sessions that will be scheduled.

3. Press the ENABLE softkey to display this screen:

```
ENABLE & SLEEP BETWEEN SURVEYS --
ENABLE & STAY AWAKE BETWEEN SURVEYS --
                                     CANCEL --
```

Press one of the ENABLE... softkeys. ENABLE & SLEE ... makes the receiver go back to sleep after each survey; ENABLE & STAY AWAKE... makes it stay awake after waking up for the first survey.

4. The keypad's TIMER indicator lights, showing that the auto-survey timer is enabled but the receiver is not yet asleep. The receiver displays this screen:

```
AUTO-SURVEY MODE ENABLED | CANCEL
DEFAULT ANTENNA HEIGHT:  | UNITS
                        00.0000 METERS |
SERIAL #: 000000         | ACCEPT
```

This screen lets you change the antenna height and serial number. If you do so, the change will apply to all of the sessions being scheduled. When you have the values, press the ACCEPT softkey. The receiver displays this screen:

```
AUTO-SURVEY MODE ENABLED | CANCEL
GOING TO SLEEP IN 30 SECONDS |
UNTIL:TUE 31-JAN-95 15:25 PST/24 |
```

The last line shows the date and time when the receiver will wake up for the first scheduled survey. When the GOING TO SLEE ... line counts down to zero, the receiver goes to sleep.



---

**Note** – If you end a survey manually (with the survey status screen's END SURVEY softkey) while the auto-survey timer is enabled, the receiver will cancel any scheduled surveys that are still waiting to run.

---

### How to Cancel the Auto-Survey Timer

You may cancel the auto-survey timer at any time. Canceling the auto-survey timer terminates the current surveying session (if any) and deschedules all scheduled sessions.

**If the receiver is awake:** You can use most functions *without* canceling the auto-survey timer. For example, you can download logged data and delete old data files. In this respect, running a session with the auto-survey timer is just like running a session manually, except that the receiver logs data only when a scheduled session is actually running.

If you must cancel the auto-survey timer:

1. Press [LOG DATA]. The *Log Data* menu will appear.
2. From the *Log Data* menu, press the END SURVEY softkey. (See the section How To End A Quickstart Session for more detailed instructions.)

**If the receiver is asleep:**

1. Press the [POWER] key to wake the receiver up. It will perform its power-up tests, then display this screen:

```
AUTO-SURVEY MODE ENABLED      |CANCEL
SLEEP INTERRUPTED             |
GOING TO SLEEP IN 30 SECONDS  |
UNTIL:WED 01-FEB-95  7:15 AM PST|
```

2. To prevent the receiver from going back to sleep, press the CANCEL softkey within the 30 second countdown period.
3. The receiver displays the *Log Data* menu. Because one or more surveys are scheduled to be run, the receiver is in data logging mode, and the *Log Data* menu looks like this:

```
SURVEY:                        |USER INPUT
                               |  CHANGES
                               |
                               |END SURVEY
```

Select END SURVEY to terminate the current survey and cancel the auto-survey timer.

### 2.3.6 Performing Other Operations During a Static Survey

Most of the receiver's functions work the same way while it is conducting a static survey as they do while it is not logging data at all. There are a few exceptions; when the receiver is conducting a static survey:

- The main *Status* screen has a different format.

```
0492-137-0 LOGGING FOR 0:01 |ELEV/AZM
APPROX. MEMORY LEFT: 94 HR |POSITION
SV02,19,06,18 | DATE
PWR2+[#####] ⚡ 2:05:03 PST/24 | MORE
```

The first line shows the data file name and the number of hours and minutes the survey has been under way.

The status screen shows whether data logging is in progress or not. Press [STATUS] and look at the screen's first line. If it shows a file name and the "Logging For" time, data is being logged. If it says something else, such as "PositioningAuto SV Select," data is not being logged.

- The [LOG][DATA] screen displays a menu that lets you end the session or modify certain parameters, instead of the standard *Log Data* menu. The menu appears on this screen:

```
SURVEY: |USER INPUT
| CHANGES
|END SURVEY
```

- The *Control* menu's LOGGEDDATA FILES item is locked out to protect files from accidental change, and the [SESSIONS] key is locked out.

The usefulness of logged data may be impaired if you change most *Control* parameters during a survey. It is safe to change only the following *Control* parameters:

- The antenna information parameters: antenna height, measurement type, antenna type, and antenna serial number.

- Elevation mask, PDOP mask, sync time, and SV Enable/Disable, *but only if corresponding changes are made on all receivers at the same time*. Changing these parameters can help you save a survey that would otherwise be spoiled; it is not recommended as a normal procedure.

## 2.4 Static Surveying and DGPS at the Same Time

On receivers that have the RTCM-104 Input Option or the RTCM-104 Output Option, it is possible to use differential GPS (DGPS) and run a static survey simultaneously.

DGPS is discussed in Chapter 5. This section discusses issues that arise when DGPS and static surveying are done simultaneously.

**Reference position.** If you selected AUTOMATIC for the survey reference position, the survey uses the positioning parameters' reference position. If the positioning reference position is not defined, it takes a position fix in autonomous mode.

**Elevation mask.** If a receiver functions as a DGPS base station while running a static survey, it uses the static survey elevation mask for positioning (and DGPS). The positioning elevation mask is ignored for the duration of the surveying session. A rover uses the positioning mask for DGPS, and the static survey mask for the survey.

**Sync time.** If either the positioning sync time or the static survey sync time is a decimal fraction, the static survey sync time is used for positioning. The positioning sync time parameter is actually set equal to the current value of the static survey sync time; it is not changed back at the end of the surveying session, and you cannot change it to a fractional value during the session.

## 3 FastStatic Surveying

---

FastStatic surveying requires simultaneous observations of at least four satellites. Data collection time is typically 5 to 40 minutes for dual frequency receivers or 20 to 30 minutes for single frequency receivers, depending on atmospheric conditions and the number of satellites available.

FastStatic surveying yields baseline components that are precise to better than  $\pm 1 \text{ cm} + 1 \text{ ppm}$ . Because of the relatively short observation time, a single rover can be used to make observations at several unknown marks in the course of a survey. The procedure is limited to operations with baselines of about 20 km or less, and it is more sensitive to cycle slips and high PDOP than static surveying is.

The FastStatic surveying procedure is very similar to the kinematic procedure, and if you have done kinematic surveying with Trimble equipment, you will probably need only a few minutes of instruction to master FastStatic surveying. As in kinematic surveying, one receiver generally remains stationary throughout a survey, while one or more rovers collect data at several survey marks in turn. The START and MOVE softkeys are similar in operation to the kinematic procedure's STATIC and ROVE softkeys.

*A Field Guidebook for Dynamic Surveying* provides another description of FastStatic surveying procedures, with emphasis on survey design and planning. A full citation is given in the bibliography of the *Series 4000 Receiver Reference*.

Figure 3-1 diagrams the FastStatic surveying procedure for a rover. The procedure for a base station is the same except that the receiver stays at the same mark throughout a survey.

### 3.1 Required Equipment and Software

A FastStatic survey requires at least two dual-frequency receivers, each equipped with a dual-frequency antenna, tripod, and tribrach.

The preferred antenna is the Compact L1/L2 Antenna with groundplane. This antenna may be used without the groundplane where multipath errors are not a problem. You may also use the L1/L2 Geodetic Antenna, a predecessor of the Compact L1/L2 Antenna, or the Permanent Reference Station L1/L2 Geodetic Antenna.

FastStatic survey results are postprocessed with GPSurvey (a Microsoft Windows application).

### 3.2 Setting Up the Equipment

**Base stations and rovers.** You must set up one or more base stations (also called *reference receivers*) at reference marks whose WGS-84 or NAD-83 coordinates are known with sufficient accuracy for your purposes.

You must set up one or more rovers (survey receivers) at survey marks whose coordinates are to be determined. These receivers are called rovers, or survey receivers.

The hardware and setup procedures for base stations and rovers are the same.



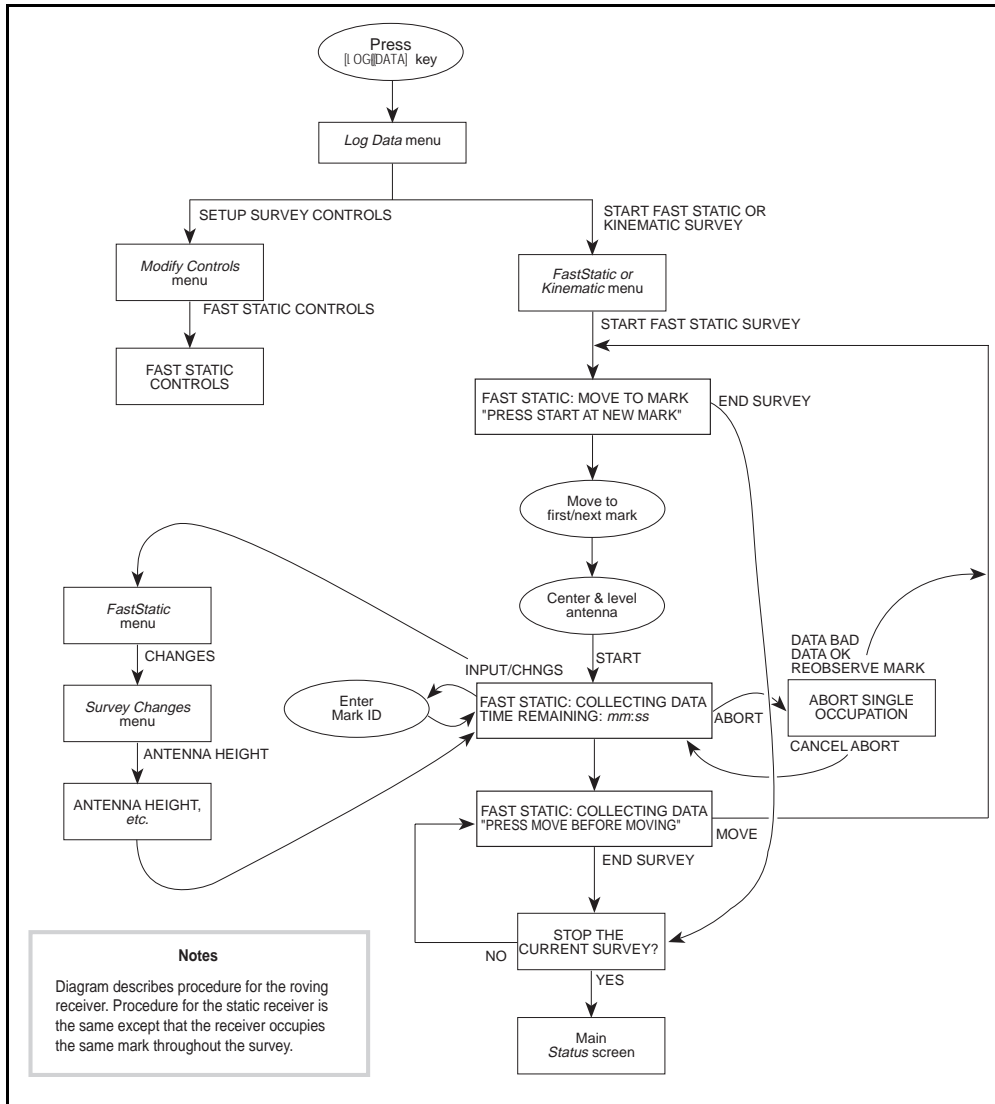

Figure 3-1. FastStatic Survey Procedure (Rover)

**To set up a receiver:**

1. Set up an antenna on a tripod; center and level the antenna and measure its height. The correct procedure is described in the section *Using and Caring for an Antenna* in Appendix A.
2. Turn the receiver on. Wait for it to complete its self-test and display the *Log Data* menu, which will look something like this:

```
QUICK-START NOW! (SINGLE SURVEY) --  
START PRE-PLANNED (SINGLE SURVEY) --  
START FAST STATIC OR KINEMATIC SURVEY --  
MORE --
```

If the receiver displays a screen similar to the one below, the last survey performed was never completed. See the section *Restarting a Session After a Power Failure* in Appendix A.

```
SURVEY RESTARTED  
  
AFTER POWER FAIL  
** PRESS ANY KEY **
```

### 3.2.1 Setting the Operating Parameters

1. To ensure that the receiver performs the survey in a known, correct state, set the power-up parameters to their default values. Select DEFAULT CONTROLS from the *Control* menu to display this screen:

```
INITIALIZE ALL CONTROLS TO DEFAULT |
SETTINGS AND RESTART RECEIVER     |
                                   | NO
                                   | YES
ARE YOU SURE ?                    |
```

Press the YES softkey and wait for the receiver to reset itself.

2. Select SETUP SURVEY CONTROLS from the *Log Data* menu. The receiver displays this screen:

```
MODIFY QUICKSTART  CONTROLS  --
MODIFY FAST STATIC CONTROLS  --
MODIFY KINEMATIC   CONTROLS  --
```

3. Select MODIFYFAST STATIC CONTROLS. The receiver displays this screen:

```
FAST STATIC SURVEY ELV MASK: +15.0 | DEFAULT
                                4 5 6 SUS | MINUS
MINIMUM MEAS TIMES: 20 15 08 MIN |
MEAS SYNC TIME : 15.0          SEC | ACCEPT
```

4. Set the parameters. The values shown in the screen above are appropriate for most applications using dual frequency receivers. Single frequency receiver times will be longer.
  - The first line shows the elevation mask for FastStatic surveys.
  - The second and third lines show minimum observation times for four, five, and six or more available satellites. For example, the screen above shows a minimum observation time of 20 minutes for four satellites, 15 minutes for five satellites, and 8 minutes for six or more satellites. For more information about minimum observation times, see below
  - The fourth line shows the sync time (the interval at which the receiver will log measurement data).

To set the recommended values, press the DEFAULT softkey, then press ACCEPT. The receiver returns to the *Log Data* menu.

**Minimum observation times.** To complete an observation, the rover must collect data from the required number of satellites *continuously* for the minimum time specified by its parameters. If its observation of any satellite is interrupted, it must ignore the measurements taken from that satellite and fall back to a longer observation time with a smaller number of satellites. If that is impossible, it must restart the observation period at the beginning. (This assumes that the base station is set up in a good location and does not suffer cycleslips. Cycleslips on the base station can also invalidate your observations if they reduce the number of satellites tracked below the minimum required for a survey, but you will not know about it until you postprocess the data.)

You can disable one or more of the minimum observation times (but not all three) by entering a value of 00. The receiver replaces “00” with “- - -” in the display

The receiver will not use a number of satellites whose observation time has been disabled. For example, if the observation time for five satellites were set to 00 in the screen shown above, the receiver would use only four satellites (with a minimum observation time of 20 minutes) unless six or more were available.

Apart from setting a minimum observation time to zero, you may not set a shorter time for 5 SVs than for 4 SVs, or a shorter time for 6 SVs than for 5 SVs. If you violate this rule, the receiver will place the cursor in the offending field and require you to change the value.

If you set all three observation times to 00, the receiver will reset all three to their default values.

### Importance of Simultaneous Observations

Because the FastStatic surveying procedure is intended for control surveying, where precision is essential, it is customary to make simultaneous observations with all of the receivers used in a given survey. This enables the postprocessing software to compute a baseline between every pair of receivers, not just between the base station and each rover. The additional baselines may then be cross-checked for consistency, increasing the precision and reliability of the results. This type of survey is called a *network* survey, as opposed to a *radial-arm* survey in which baselines are computed only between each rover and the base station.

### 3.2.2 Performing a FastStatic Survey

To run a FastStatic survey on a rover (a surveying receiver) you must:

1. Press the [ F ] key; then select START FAST STATIC OR KINEMATIC SURVEY; then select START FAST STATIC SURVEY. This displays the main FastStatic screen.
2. Go to the first (or next) mark and set up the antenna.
3. Press the START softkey to start an observation.

4. During the observation, enter the mark ID and antenna parameters. You may also enter field notes and event marks, and check the receiver's status.
5. Wait until the receiver shows that it has collected sufficient data.
6. If the survey is not complete, end the observation by pressing the MOVE softkey; return to step 2 to survey the next mark.
7. If the survey is complete, press the END SURVEY softkey. This ends the FastStatic surveying procedure.

The procedure for a base station receiver is the same, except that the receiver “surveys” only one mark. In other words, you omit steps 4 through 7.

### Step 1: Display the Main FastStatic Screen

1. Press the [LOG] key. The receiver displays the *Log Data* menu. The menu looks like one of these examples, depending on whether the receiver has the Kinematic Functions Option or not:

```
QUICK-START NOW! (SINGLE SURVEY) --
START PRE-PLANNED (SINGLE SURVEY) --
START FAST STATIC OR KINEMATIC SURVEY --
                                     MORE --
```

```
QUICK-START NOW! (SINGLE SURVEY) --
START PRE-PLANNED (SINGLE SURVEY) --
START FAST STATIC SURVEY --
                                     MORE --
```

Select START FAST STATIC.. ..

2. *If the receiver has the Kinematic Functions Option*, it displays this menu:

```

START FAST STATIC SURVEY --
START KINEMATIC SURVEY --

```

Select START FAST STATIC SURVEY.

3. The receiver displays the FastStatic survey screen:

```

FAST STATIC: MOVE TO MARK | START
                    | INPUT/CHNGS
TRACKING 5 SVs          |
*** PRESS START AT NEW MARK! END SURVEY

```

The first line shows the survey's current status: ready to move to a mark.

The fourth line displays a scrolling message that tells you what to do next.

**About the scrolling message.** The scrolling message is intended to catch your eye and give you important information about what to do next. When a scrolling message is displayed, you can restart it at any point by pressing [C] EAR].

**Antenna not required.** The antenna need not be set up, or even connected to the receiver, when this step is performed. It is helpful to set up the antenna at the beginning of the procedure, though, so that the receiver can get a position fix before you start the survey.

### Step 2: Set Up the Antenna

Go to the first (or next) mark, if necessary, and set up the antenna. Center and level the antenna and measure its height. The correct

procedure is described in the section Using and Caring for an Antenna in Appendix A.

### Step 3: Start an Observation

Press the START softkey to start the observation. The antenna must remain stationary from this point to the end of the observation.

The receiver displays this screen:

```
FAST STATIC: COLLECTING DATA |
MARK ID: ___0001 5 SVs | ABORT
TIME REMAINING: 14:59 | INPUT/CHNGS
                           | END SURVEY
```

**Wait for data at first mark.** At the first mark only, the receiver must initialize certain data logging functions before it starts the observation. While that is happening, the first line of the screen briefly says WAIT FOR DATA; then it changes to COLLECTINGDATA.

**Time remaining may increase or decrease.** The observation time remaining, displayed on the last line, is a prediction based on the settings of the FastStatic data logging parameters and the current observation conditions. It may increase or decrease during the observation if conditions change. In any case, you can be sure that the receiver has collected enough data for a valid observation when the time remaining reaches zero.

**Too few satellites to continue observation.** If the number of satellites required by the data logging parameters is not available, the receiver displays this screen:

```
FAST STATIC: COLLECTING DATA |
MARK ID: ___0001 4 SVs | ABORT
TIME REMAINING: NEED 5 SVs | INPUT/CHNGS
                           | END SURVEY
```



This example shows that the data logging parameters require five satellites to conduct an observation, and only four are available.

If this happens you may wait for the required number of satellites to become available again, or you may abort the observation. If you abort the observation you may change the data logging parameters to reduce the required number of satellites, then restart the observation.

#### **Step 4: Enter Mark ID and Antenna Parameters**

Before the end of the observation you must enter the mark's ID and the antenna parameter values. You may also enter field notes and event marks, and you may check the receiver's status. You may do these things at any time during the observation, and in any order.

**To enter the mark ID.** During the observation, the cursor is in the MARK ID field. To enter the mark ID, fill in the first four characters.

The mark ID is eight characters long. The first four characters customarily are filled with an alphanumeric code that uniquely identifies each mark for a given survey. The receiver fills the rest of the field with a sequence number that starts at 1 and increases by 1 for each additional observation at the same mark. You can change the mark ID manually if necessary.



---

**Note** – You may enter the mark ID as soon as the main FastStatic screen appears. During the first observation you need not wait until WAIT FOR DATA is replaced by COLLECTING DAT .

---

**To enter the antenna parameters.** Follow the procedure described in the section Entering Antenna Parameters in Appendix A.

**To enter field notes or event marks.** Field notes are alphanumeric notes associated with a survey. Event marks are alphanumeric notes associated with a specific time in a survey. Both are available as descriptive information in postprocessing programs. The procedures

for entering both types of data are described in the section Entering Supplementary Data in Appendix A.

### Step 5: Wait While the Receiver Collects Data

When the time-remaining counter on the last line of the status display reaches zero, the receiver displays the MOVE softkey, beeps, and displays the scrolling message “PRESS MOVE BEFORE MOVING”:

```
FAST STATIC: COLLECTING DATA | MOVE
                               | ABORT
MARK ID: FLDC0001    5 SUs | INPUT/CHNGS
** PRESS MOVE BEFORE MOVING | END SURVEY
```

This shows that the receiver has collected enough data for a valid observation.

**Additional observation time improves results.** If you allow the receiver to continue collecting data after the MOVE softkey appears, the additional data will allow the postprocessing program to produce a more accurate result by averaging out multi-path interference.

**Too few satellites to continue observation.** If the number of available satellites drops below 2 (the minimum required to form a double-difference) after the receiver has collected sufficient data for a valid observation, this screen appears:

```
FAST STATIC: SUFFICIENT DATA!      MOVE
                                     |      ABORT
MARK ID: FLDC0001    2 SVS | INPUT/CHNGS
** PRESS MOVE BEFORE MOVING | END SURVEY
```

You may end the observation or wait for the number of available satellites to increase.

### Step 6: End the Observation

**Survey not complete.** To end the observation, press the MOVE softkey. Wait for the scrolling message PRESS STARTAT NEW MARK to appear, then move your equipment to the next mark. Return to the section Step 2: Set Up the Antenna.

**Survey complete.** To end the observation and the survey, press the END SURVEY key. The receiver displays this screen:

```
STOP THE CURRENT SURVEY?      | YES
                               |
                               |
                               | NO
```

Press YES to end the survey and return to the *Log Data* menu.



**Note** – You must press MOVE or END SURVEY before moving or disconnecting the antenna. If you neglect this step, the observation's data will be corrupted.

You may also press the END SURVEY softkey when the receiver is in *Move* mode (waiting to be moved to a new mark). The END SURVEY softkey is available in both modes.

### 3.2.3 Aborting an Observation

You can abort an observation at any time, before or after the receiver has collected sufficient data. This is most often useful when you accidentally press START before the antenna is centered and leveled, or the antenna is disturbed during an observation.

To abort an observation, press the ABORT softkey:

```
FAST STATIC: COLLECTING DATA | MOVE
                          | ABORT
MARK ID: FLDC0001    5 SVS | INPUT/CHNGS
** PRESS MOVE BEFORE MOVING | END SURVEY
```

The receiver displays this screen:

```
ABORT SINGLE OCCUPATION | DATA BAD
                          | DATA OK
                          | REOBSERVE MARK
                          | CANCEL ABORT
```

Press one of the softkeys:

- DATA BAD flags the data as suspect and increments the mark ID. This is the appropriate choice if the antenna must be moved (or has been disturbed).
- DATA OK flags the data as possibly processable and increments the mark ID. This is an appropriate choice only if the MOVE softkey has not yet appeared *and* the antenna has not been moved.

- REOBSERVE MARK is equivalent to DATA BAD, but does not increment the mark ID. If you accidentally press REOBSERVE MARK instead of DATA BAD, you should increment the mark ID manually.
- CANCEL ABORT redisplay the main FastStatic screen and allows the observation to continue undisturbed.

An observation is also aborted if you press the END SURVEY softkey before sufficient data is collected for a valid observation (before the MOVE softkey has appeared). This is equivalent to pressing DATA OK, except that it ends the survey as well as aborting the observation.

### 3.2.4 Displaying Satellite Tracking Information

To display satellite tracking information during an observation, press the INPUT/CHNGS softkey to display this screen:

```
FAST STATIC: |
              | USER INPUT
              |   CHANGES
              |   STATUS
```

Press the STATUS softkey to display this screen:

```
CONTINUOUS TRACKING TIMES: |
      [4]      5      6  SU= |
REQUIRE:  __:__  15:00  8:00  | CURRENT
      BEST: 10:16  10:16  2:00  | RETURN
```

- Line 2 shows numbers of satellites. The '6' column actually represents "six or more."

- Line 3 shows the minimum measurement times required for four, five, and six or more satellites by the FastStatic data logging parameters. (See the section Setting the Operating Parameters.)

If any of the minimum measurement times was entered as 0:00, disabling the corresponding minimum observation time, the number on line 2 is in brackets, and the value on line 3 is displayed as ‘\_:\_’.

- Line 4 shows the durations of the best (longest) continuous measurement times. If any of the values on line 4 is greater than the corresponding value on line 3, the MOVE softkey is available on the main FastStatic screen.

**To display current continuous measurement times.** To make line 3 show the durations of the current continuous measurement times, press the CURRENT softkey:

```

CONTINUOUS TRACKING TIMES: |
      [4]      5      6  SU= |
CURRENT:  _:_  05:54  0:00  | REQUIRE
      BEST: 10:16  10:16  2:33  | RETURN
  
```

This screen shows that the current continuous measurement time for four satellites is the best time, at 10 minutes, 16 seconds. A fifth satellite's availability has been interrupted; the current measurement time is 5:54, while an earlier continuous measurement period lasted 10:16. The current measurement time for six satellites is zero, indicating that six satellites are not currently available.

Press the REQUIRE softkey to redisplay the minimum required measurement times.

**To leave the status screen.** Press the RETURN softkey to redisplay the main FastStatic screen.

### 3.2.5 Creating a Log Data File for Each Observation

As described above, the FastStatic surveying procedure creates one data file for the entire survey. This approach is customary because it simplifies the task of file management.

It is also possible to create a separate file for each survey mark; simply perform a separate survey for each observation. The receiver will create a separate file for each survey.

### 3.2.6 Turning Power Off Between Marks

In general it is undesirable to turn the receiver off between observations. If you do so the receiver will create a new data file each time it is restarted, and you will have to keep track of all of the data files and combine them for postprocessing. You also will have to wait for the receiver's startup procedure each time you turn it on.

Since the only "cost" of leaving the power on is that it shortens the effective life of a battery charge, it is simpler to just carry some extra batteries.

If you must turn the receiver off between observations, you should end a survey before turning it off and start a new survey when you turn it back on. You will probably want to combine the resulting log files after downloading them, so that the postprocessing program can treat them all as parts of a single survey.

Since it is possible to resume a survey after a power failure, it is theoretically possible to turn the power off between marks by pressing the MOVE softkey, then powering off. The receiver will restart in the *Move* mode when powered on. This technique is not recommended, though, because it does not store a header at the beginning of the new file. In any case, it still produces multiple data files.





## 4 Kinematic Surveying

---

There are three types of kinematic surveying: stop-and-go, continuous, and leapfrog.

*Stop-and-go* kinematic surveying is very similar to FastStatic surveying. It requires only a brief observation (typically one to two minutes) at each survey mark. It uses the L1 carrier and L1 C/A code instead of FastStatic's P-code on the L1 and L2 channels.

*Continuous* kinematic surveying does not require the rover to stop at discrete marks; it simply makes an observation every epoch, even if the rover is moving. It is useful for certain aerial and marine surveying applications, and for non-surveying applications such as monitoring the path of a vehicle. It has essentially the same precision as stop-and-go kinematic surveying, but is more susceptible to multi-path interference.

Note that the differences between stop-and-go and continuous kinematic surveying are all in field procedure and postprocessing; the firmware options used are the same in both. The data that a stop-and-go kinematic survey collects between survey marks may be used like the data collected in a continuous kinematic survey. You may view a continuous kinematic survey as a stop-and-go kinematic survey without stops.

*Leapfrog* kinematic surveying is similar to stop-and-go surveying, but lets the base station and rover trade roles during the survey. That is, at some point the rover assumes the function of a base station; the original base station can then become a rover. Leapfrog surveying can extend the range of a kinematic survey beyond its basic 15km limit,

but requires very careful coordination to ensure that both stations never move at the same time. Leapfrog surveying is discussed in *A Field Guidebook for Dynamic Surveying*.

All types of kinematic surveying are precise to  $\pm 2 \text{ cm} + 2 \text{ ppm}$ . Like the FastStatic procedure, they are sensitive to loss of lock on the satellites throughout the survey. They are also sensitive to high PDOP conditions and multipath interference, either of which can interrupt a survey if they affect a receiver even briefly.

You can do stop-and-go and continuous kinematic surveying at the same time simply by making the postprocessor compute baselines from the data logged while moving between survey stations as well as the data logged while observing the stations. This approach is useful for creating profiles or contour maps.

The following sections discuss the kinematic surveying procedure in this order:

1. Planning for a kinematic survey.
2. Equipment and software required.
3. Using a data collector for kinematic surveying.
4. How to set the data logging parameters.
5. How to initialize a kinematic survey.
6. How to perform a stop-and-go kinematic survey.
7. How to perform a continuous kinematic survey.
8. How to end a kinematic survey of either type.
9. Other aspects of kinematic surveying, such as how to abort a suspect observation and how to recover from loss of lock on satellites.

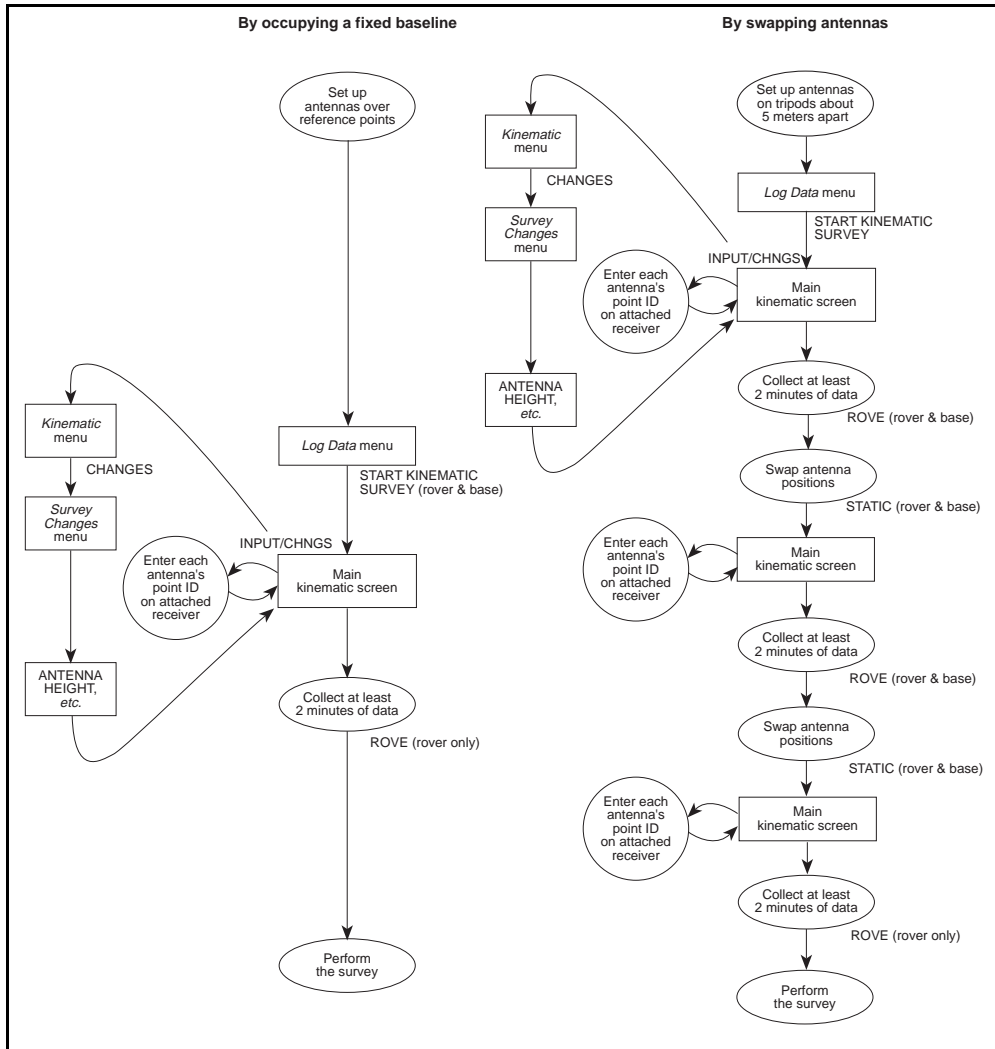

Figure 4-1. Initialization for Kinematic Surveying Procedure

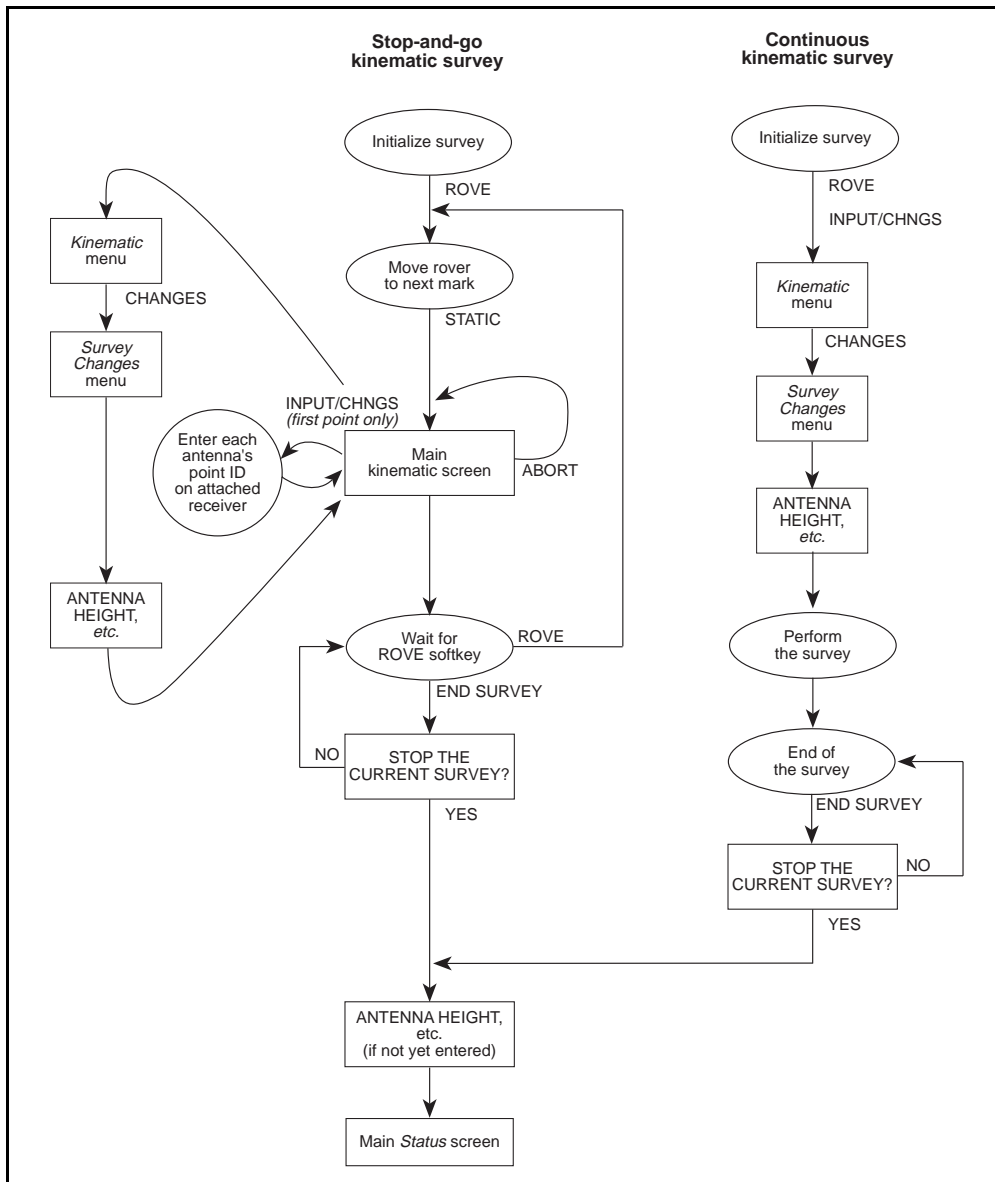

Figure 4-2. Kinematic Surveying Procedure

## 4.1 Planning for a Kinematic Survey

Planning for a kinematic survey is particularly important because the procedure is so sensitive to loss of lock.

For suggestions on how to establish reference marks and survey marks to minimize loss-of-lock problems, see the section Site Preparation and Planning in Appendix A. The ideas in that section will also help you set up and operate the surveying equipment once the marks have been chosen.

### 4.1.1 Reference Marks

To prepare for a kinematic survey you must establish a network of reference marks, also known as control marks. Each base station will occupy a reference mark; other reference marks may be needed to initialize rovers, and to reinitialize them if they lose satellite lock.

The coordinates of each reference mark must be known in relative WGS-84 coordinates before the kinematic survey data is postprocessed. The precision of the reference mark coordinates must be at least as great as the precision required of the survey results. The minimum precision required for a successful survey is  $\pm 10$  meters.

If you are initializing by occupying a fixed baseline, you must know the baseline (the difference between the reference marks at the end of the baseline) to a precision of  $\pm 5$  cm.

In principle the reference mark coordinates may be determined *after* the kinematic survey, but this is generally unwise: if an unexpected problem prevents you from determining the reference marks' WGS-84 coordinates, the entire survey will have to be repeated.

### 4.1.2 Number of Receiver

You can perform a kinematic survey with just one base station and one rover. You can increase surveying efficiency by adding any number of additional rovers.

You also can use additional base stations. This has several potential advantages: avoiding the problems associated with a radial-arm survey, widening the area the survey can cover, guarding against loss of lock on the base station, and collecting additional data that can be used to cross-check the survey results. The section Using Multiple Base Stations discusses procedures for working with multiple base stations; you should read it before planning such a survey. *A Field Guidebook for Dynamic Surveying* discusses this matter in more detail.

### 4.1.3 Satellite Availability

The kinematic surveying procedure requires at least four trackable satellites; you can set the kinematic data logging parameters to require more.

Perform the survey during a period when at least five satellites (ideally more) will be available at all times. This will give you some protection against poor satellite geometry and against survey interruptions caused by a momentary loss of lock on one satellite.

### 4.1.4 Assigning Point IDs

You must identify each reference mark with a unique eight-character *point ID*. (The kinematic procedure traditionally uses the term *point* instead of *mark*.)

In a stop-and-go survey, each survey mark must have a unique point ID as well. Continuous kinematic surveys, by their nature, do not use survey marks.

Devise a procedure to ensure that each mark used in a survey has a unique point ID, and that each point is identified by the *same* point ID every time it is occupied in a given survey. Make sure that the operators will have no trouble determining which point ID represents which mark. The most reliable approach is to assign an ID to each mark when planning the survey, and label each mark with its ID when the mark is staked out.

If survey marks are to be chosen and staked during the survey, the roving operators must understand how to assign unique point IDs and record them clearly. Field notes are a convenient tool for this purpose. If the rover is equipped with a Survey Controller or Seismic Controller, data entry will be easier and feature codes can be used as well.

## 4.2 Equipment and Software Require

For each base station you must have:

- A receiver with the Kinematic Functions Option.
- An appropriate power source. Carry enough batteries to last through the survey at the rate of 9 hours per 6AH battery, 15 hours per 10 AH battery, or 2 hours per fully charged camcorder battery.
- An antenna and a 3-meter antenna cable.

The preferred antenna is the Compact Dome Antenna. You may also use the Compact L1 Antenna with groundplane, the Compact L1/L2 Antenna with groundplane, the L1 Geodetic Antenna, or the L1/L2 Geodetic Antenna.

- Two tripods, each with tribrach and optical plummet, and one quick-release bayonet.

For each rover you must have:

- A receiver with the Kinematic Functions Option.
- An appropriate portable power source. Trimble recommends a dual or quad battery input cable and enough camcorder batteries to last through the survey at the rate of about 2 hours per fully charged battery.
- An antenna and a 3-meter antenna cable. The same antennas are appropriate for a rover as for a base station, although the geodetic antennas' groundplanes may make them awkward to handle. The Compact L1/L2 Antenna may be used without its groundplane.

Note that if you will initialize the survey by swapping antennas, the base station and rover antennas must be the same type.

- A rangepole with quick-release adapter and bayonet. A bipod or tripod support (optional, but strongly recommended) will help to stabilize the rangepole during observations.
- A backpack.
- A Seismic Controller or Survey Controller (optional but strongly recommended; see below). The rangepole's data collector bracket may be used to mount this device on the upper part of the rangepole.

The recommended software package for postprocessing kinematic survey results is TRIMVEC Plus.



### 4.3 Notes on Using a Survey Controller or Seismic Controller

The Survey Controller and Seismic Controller are handheld devices designed to control a roving receiver. They use the same hardware but different firmware. A Survey Controller or Seismic Controller is optional equipment for kinematic surveying, but its use is strongly recommended.

The procedures for conducting a kinematic survey with and without a controller are quite different in detail, although they are based on the same principles. The procedure for using a receiver alone is described here; the procedure for using a receiver with a controller is described in the *Survey Controller Operation Manual*.

The procedure for the base station is the same (as described here) whether the roving receiver is used with a controller or not.

### 4.4 Setting Parameters

There are two sets of parameters whose values are critical to the success of a kinematic survey: the POSITIONING MODE parameters on the *Control* menu, and the kinematic data logging parameters in the *Log Data* menu.

#### 4.4.1 General Parameter Settings

To ensure that the receiver performs the survey in a known, correct state, set the power-up parameters to their default values. Select DEFAULT CONTROLS from the *Control* menu to display this screen:

```
INITIALIZE ALL CONTROLS TO DEFAULT |
SETTINGS AND RESTART RECEIVER     |
                                   | NO
ARE YOU SURE ?                    | YES
```

Press the YES softkey and wait for the receiver to reset itself.

#### 4.4.2 Positioning Mode Parameters

To set the positioning mode parameters to their standard values, press the [CONTROL] key, then select POSITIONING MODES from the *Control* menu. The receiver displays this screen:

```
POSITIONING MODES:
      L1 IONO MODEL <-- CHANGE
WEIGHTED SOLUTION ENABLED <-- CHANGE
LAT/LON OR LAT/LON/HEIGHT <-- CHANGE
```

Set the parameters to the default values shown above.



---

**Note** – Setting these parameters to other values may impair the validity of survey results.

---

### 4.4.3 Kinematic Data Logging Parameters

These parameters control the way data is logged for a kinematic survey.

The default data logging parameters (shown below) are appropriate for most surveys, so you may not need to use this screen. If you need to check or modify these parameter settings, though, you must do so before you start a survey. All data logging parameters must be set to the same values on all receivers used in a given survey.

To change the data logging parameters:

1. Press the [LOG][DATA] key. The receiver displays the *Log Data* menu.
2. Select SETUP SURVEY CONTROLS. The receiver displays this screen:

```

MODIFY QUICKSTART  CONTROLS  --
MODIFY FAST STATIC CONTROLS  --
MODIFY KINEMATIC  CONTROLS  --

```

3. Select MODIFY KINEMATIC CONTROLS. The receiver displays this screen:

```

KINEMATIC CONTROLS      |
STORE POSITION:  NORMALLY |CHANGE
ELEVATION MASK: +15' MIN SVs: 04 |MINUS
MEAS SYNC TIME: 015.0 SEC      |ACCEPT

```

4. Set the parameters as appropriate.

The parameters and softkeys are the same as the ones in the QUICKSTART CONTROLS screen. See the section How to Inspect or Modify the Quickstart Controls in Chapter 2.

For kinematic surveys, the recommended elevation mask is  $15\frac{1}{2}$ .

For stop-and-go surveys, set the sync time to a value between 1 and 5 seconds. Small values yield shorter occupation times, but fill the receiver's memory faster. For continuous surveys, a sync time of 1.0 or 0.5 second is usually appropriate. In general, use a short sync time if the receiver is moving fast, and a longer one if it is moving slowly.

MIN SVs should be set to a value greater than 4 if at all possible, as the section Satellite Availability explains.

When you perform a kinematic survey on a 4000SE Land Surveyor, remember to set the DATA FORMAT parameter to COMPACT.

## 4.5 Initializing a Kinematic Survey

There are two ways to initialize a kinematic survey:

- By occupying a fixed baseline; that is, by positioning each antenna on a reference mark. This is the preferred initialization procedure, since it is faster and it does not require the rover to be near the base station.

The procedure uses two reference marks. The coordinates of the base station's reference mark must be known with sufficient precision for the purposes of the survey. The baseline from the rover's reference mark to the base station's mark must be known with precision of 5cm or better.

- By swapping antennas. This method involves taking a kinematic observation, then swapping the positions of the base station and rover antennas and taking another observation, then swapping the antenna positions again and taking a third observation.

This method is used mainly for very localized surveys. It requires the two antennas to be at the same site. It is an expedient method when pre-surveyed reference points are not available; you can set up the antennas in any convenient positions, get on with the survey, and determine the base station's antenna position later

The following sections describe each method.

#### 4.5.1 How to Initialize by Occupying a Fixed Baseline

This initialization method requires two reference marks which are accurate to  $\pm 5$  cm. There are no lower or upper limits on the separation between the marks, although poor atmospheric conditions sometimes make it impossible to initialize a survey (or conduct one) at distances over 10 km. Because the reference marks do not have to be near each other, this method is particularly useful for reinitializing a survey in the field.

1. Set up a tripod and tribrach over each reference mark and mount an antenna on it. Use a quick-release adapter and bayonet to mount the rover's antenna.
2. Connect each receiver to its antenna and power source, then turn on both receivers. Level each tribrach, then attach the antenna to the tribrach.
3. At the base station, press the [LOG] key to display the *Log Data* menu.
4. *Dual-frequency receivers:* The *Log Data* menu looks like this:

```

QUICK-START NOW! (SINGLE SURVEY) --
START PRE-PLANNED (SINGLE SURVEY) --
START FAST STATIC OR KINEMATIC SURVEY --
                                     MORE --

```

Select START FAST STATIC OR KINEMATIC SURVEY. The receiver displays this menu:

```

START FAST STATIC SURVEY --
START KINEMATIC SURVEY --

```

Select START KINEMATIC SURVEY.

5. *Single-frequency receivers:* The *Log Data* menu looks like this:

```

QUICK-START NOW! (SINGLE SURVEY) --
START PRE-PLANNED (SINGLE SURVEY) --
START KINEMATIC SURVEY --
MORE --

```

Select START KINEMATIC SURVEY.

6. The receiver displays the main kinematic survey screen:

```

KINEMATIC MODE: STATIC WAIT |
DATA SET: 1 SVs: 4 |
POINT ID: _____ | INPUT/CHNGS
4SV EPOCHS:0 | END SURVEY

```

7. Enter the base station antenna's point ID.
8. Enter the base station's antenna height and other parameters as explained in the section Entering Antenna Parameters in Appendix A.
9. Repeat steps 3 through 8 on the rover, using the rover antenna's point ID in step 7 and the rover antenna's parameter values in step 8.

10. Allow the receivers to collect at least eight simultaneous epochs of data. For best results, collect at least two minutes of data.
11. On the rover, press the ROVE softkey. Remove the rover's antenna from the tripod and attach it to a rangepole equipped with a quick-release bayonet. *Do not turn off either receiver or let it lose satellite lock at any time, or you will have to repeat the initialization procedure.*

You are now ready to perform the survey

#### 4.5.2 How to Initialize by Swapping Antennas

This method requires one reference mark whose position is known with the degree of precision required for the results of the survey. Another mark, which we will call the *secondary mark*, should be established 3 to 5 meters (9 to 15 feet) away. The secondary mark must be assigned a point ID, and its location should be staked so that it can be reoccupied if necessary, but its coordinates need not be known. The base station and rover(s) must use the same type of antenna.

1. Set up one tripod over the reference mark and mount the base station's antenna on it, using a quick-release adapter and bayonet. Set up another tripod over the secondary mark and mount the rover's antenna on it, also using a quick-release adapter and bayonet.

Connect each receiver to its antenna and power source. Turn on both receivers. Level the antennas.

2. On the base station receiver, press the [LOG] key to display the *Log Data* menu.

3. *Dual-frequency receivers:* The *Log Data* menu looks like this:

```

QUICK-START NOW! (SINGLE SURVEY) --
START PRE-PLANNED (SINGLE SURVEY) --
START FAST STATIC OR KINEMATIC SURVEY --
                                     MORE --

```

Select START FAST STATIC OR KINEMATIC SURVEY The receiver displays this menu:

```

START FAST STATIC SURVEY --
START KINEMATIC SURVEY --

```

Select START KINEMATIC SURVEY.

4. *Single-frequency receivers:* The *Log Data* menu looks like this:

```

QUICK-START NOW! (SINGLE SURVEY) --
START PRE-PLANNED (SINGLE SURVEY) --
START KINEMATIC SURVEY --
                                     MORE --

```

Select START KINEMATIC SURVEY.

5. The receiver displays the main kinematic survey screen:

```

KINEMATIC MODE: STATIC WAIT |
DATA SET: 1                SVs: 4 |
POINT ID: _____      | INPUT/CHNGS
4SV EPOCHS:0                | END SURVEY

```



Enter the point ID of the reference mark.

6. Enter the antenna parameters as explained in “Entering Antenna Parameters” on page 193.
7. Repeat steps 2 through 6 on the rover, entering the point ID of the secondary mark in step 5, and the rover antenna's values in step 6.
8. Allow the receivers to collect at least 20 simultaneous epochs.
9. Press the ROVE softkey on each receiver.
10. Dismount the receivers' antennas and swap them; that is, mount the base station's antenna on the tripod over the secondary mark, and the rover's antenna on the tripod over the reference mark. Take care not to disturb the tripods, since each antenna must occupy the exact position that the other one occupied before the swap. *Do not turn off either receiver or allow it to lose satellite lock at any time.*
11. Press the STATIC softkey on each receiver. Enter the swapped antennas' point IDs on both receivers: the secondary point's ID on the base station receiver, and the reference mark's ID on the rover.
12. Allow the receivers to collect at least 20 simultaneous epochs or two minutes of data.
13. Repeat the procedure described in steps 9 through 11 to swap the antennas back to their original positions. Remember to press ROVE before touching the antennas, and STATIC after remounting them.
14. Allow the receivers to collect at least 20 simultaneous epochs or two minutes of data.
15. Press the ROVE softkey on the rover *only*. Remove the rover's antenna from the tripod and attach it to a rangepole equipped with a quick-release bayonet. *Do not turn off either receiver or let it lose satellite lock at any time, or you will have to repeat the initialization procedure.*

---

You are now ready to perform the survey

## 4.6 Using Multiple Base Stations

You can conduct a kinematic survey with two or more base stations at different sites. This approach has several advantages. It gives protection against loss of lock on the base station; any misfortune that affects one presumably will not affect the other. It also lets you conduct a kinematic survey over an area wider than the 1.5 km radius that a single base station can serve.

Multiple base stations enable the postprocessor to detect a variety of data collection problems, such as high PDOP and poor initialization technique. To make this possible, though, you must occupy each survey mark at least as many times as there are base stations, with at least 1.5 minutes between occupations. If there are two base stations, for example, occupy each survey mark twice; if there are three, occupy each survey mark three times. In this way you will collect a set of independent observations sufficient to take full advantage of the base stations you have set up.

The procedure for initializing a survey with multiple base stations is straightforward: just repeat the basic initialization procedure for each base station. If you have three rovers and two base stations, for example, you must perform six initializations: one for each rover paired with each base station.

The method of initializing a survey with a fixed baseline has the advantage that you can initialize any number of base stations and rovers at the same time. Simply set them all up at appropriate reference marks and arrange to make all of them collect data simultaneously. Remember that the baselines from the base station to *all* of the rovers must be known.

## 4.7 Performing a Stop-and-Go Kinematic Survey

This procedure assumes that the survey has been initialized. The base station is collecting data at the reference mark; the rover is in *Rove* mode, and its antenna has been attached to a rangepole.

1. Move the rover to the first (next) mark to be surveyed.
2. Position the antenna over the mark. Set up the rangepole's support so that you can let go of the rangepole while you perform the next few steps.
3. Press the **STATIC** softkey. The **STATIC** softkey disappears from the display, and the status **STATIC WAIT** appears on the first line.
4. Enter this survey mark's eight-character point ID.

If the rover's consecutive survey marks are assigned consecutive point IDs, you normally will have to enter an ID only for the first mark; the receiver will increment the last four characters of the ID each time you press the **STATIC** softkey. Check the ID for each mark, though, to be sure that its point ID is correct.

5. *First survey mark only:* Press the **INPUT/CHNGS** softkey to display this menu:

```
KINEMATIC: |
              |
              | USER INPUT
              |   CHANGES
              |
```

Select **CHANGES**. Set the antenna parameters as explained in the section **Entering Antenna Parameters** in Appendix A.

This step is not necessary for subsequent marks unless the antenna height has changed for some reason.

6. Allow the rover to collect at least two epochs of data. When the rover has collected sufficient data for a valid observation, the first line's message changes from STATIC WAIT to STATIC, and the ROVE softkey appears.



---

**Note** – Trimble strongly recommends collecting more data than the two-epoch minimum. Collecting at least eight epochs of data may improve the quality and reliability of the measurements.

---

7. Select ROVE.
8. If there are more marks to survey, return to step 1.  
If there are no more marks to survey, end the survey as described in the section Ending a Survey.

**At all times, remember:**

- Press ROVE before you move the antenna at the end of an observation.
- Handle the antenna so as to avoid losing lock on the satellite signals at any time. When handling the rangepole or antenna, keep your hands below the antenna plane.

**Other means of antenna support.** It is sometimes appropriate to use an antenna support other than a rangepole.

In the most common case, the antenna is mounted on a pole fixed to a vehicle such as a jeep. The surveying procedure is the same as described above, except that you must ensure that the antenna is vertical whenever a survey mark is being occupied.

## 4.8 Performing a Continuous Kinematic Survey

This procedure assumes that the survey has been initialized. The base station is collecting data at the reference mark; the rover is in *Rove* mode, and its antenna has been attached to the rangepole.

1. Press the INPUT/CHNGS softkey to display this menu:

```
KINEMATIC: |
             | USER INPUT
             |   CHANGES
             |
```

2. Select CHANGES. Set the antenna parameters as explained in the section Entering Antenna Parameters in Appendix A.  
  
Give some thought at this point to the significance of “height.” If you carry the rover's antenna about by hand, its height may vary over a range greater than the precision of the survey. It is better to mount the antenna on a pole attached to your backpack (and maintain good posture consistently while logging data). If you have attached the antenna to a vehicle, measure its height to the ground. Be aware that operating the vehicle on a slope will add some error to the results.
3. Now you may move the rover about as appropriate.
4. When the survey is complete, end it as described in the section Ending a Survey, below.

**At all times, remember:**

- Keep the antenna support vertical if accurate heights and positions are important.
- Handle the antenna at all times so as to avoid losing lock on the satellite signals. When handling the antenna or support, keep your hands below the antenna plane.

## 4.9 Ending a Survey

This section describes the procedure for ending a kinematic survey, either stop-and-go or continuous.

1. While not strictly necessary, it is good practice to reinitialize the rover at the end of the survey. This ensures that you will have at least two initializations to cross-check during postprocessing, and gives an extra margin of protection against loss of lock.

You may use any of the initialization methods described earlier in this chapter, but initialization by occupying a fixed baseline is usually the only practical method. The section Reinitializing a Survey gives information about this matter.

2. To end the survey, press the END SURVEY softkey. The rover displays this screen:

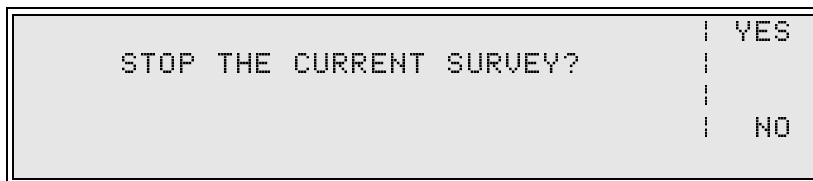

Press YES to end the survey.

3. *Stop-and-go survey:* If you have not entered antenna parameters since starting the last observation (the usual case, since the parameter values normally do not change), the receiver displays the ANTENNAPARAMETERS screen. Just press ACCEPT. The receiver displays the main *Status* screen.
4. *Continuous survey:* If you have not entered antenna parameters, the receiver displays the ANTENNA PARAMETERS screen. Enter the antenna parameters now and press ACCEPT. The receiver displays the main *Status* screen.
5. Return to the base station and repeat steps 2 through 4 on the base station receiver.

If you are conducting a stop-and-go survey and you have followed the published procedure conscientiously, you will be in *Rove* mode when you start the “end a survey” procedure. However, you may also end the survey by pressing the END SURVEY softkey while the receiver is in *Static* mode, without pressing ROVE first. This simply ends the last observation and the survey in a single step.

## 4.10 Reading the Main Kinematic Screen

During most parts of the kinematic surveying procedure, the screen resembles this one:

```
KINEMATIC MODE: STATIC WAIT |
DATA SET: 1          SVs: 4 | ABORT
POINT ID: 00001111 | INPUT/CHNGS
EPOCHS WITH 4 SVs: 1 | END SURVEY
```

The lines of the screen are:

1. Shows the kinematic surveying procedure's current status:
  - ROVING: In *Rove* mode; the receiver is ready to move.
  - STATIC WAIT: In *Static* mode; the receiver is collecting data.
  - STATIC: In *Static* mode; the receiver is collecting data, but has collected enough to ensure a valid observation. Press the ROVE softkey to go to *Rove* mode before moving the antenna.
2. The message NOT LOGGING indicates that the receiver is acquiring satellites and calibrating itself. This process requires a few seconds at the beginning of each survey.

For the rest of the survey, lin e2 shows the number of observations that have been made and the number of satellites being tracked.

3. The point ID of the mark currently or most recently occupied.
4. The minimum number of satellites the receiver must track in order to log data, and the number of epochs of data collected so far in this observation.

If the receiver was unable to maintain its lock on the minimum required number of satellites, this line shows the message RETURN TO A PREVIOUS MARK.

## 4.11 Aborting an Observation

You can abort an observation at any time. This is most often useful when the antenna has been bumped, or was incorrectly positioned.

To abort an observation, press the ABORT softkey. The receiver goes to *Rove* mode. Reposition the antenna or do whatever else is necessary, then press the STATIC key to restart the aborted observation.

## 4.12 Reinitializing a Survey

The kinematic surveying procedure is sensitive to loss of satellite lock caused by cycleslips. A combination of cycleslips that leaves the rover tracking fewer than four satellites will interrupt the survey and abort any observation that is being made.

If the incident that interrupted the survey is liable to happen again, you should take appropriate steps to avoid it. For example, if the receiver lost satellite signals because you passed too near an obstruction, choose another path that avoids that obstruction.

When loss of lock interrupts a survey the rover sounds a kinematic alarm, displays the message RETURN TO A PREVIOUS MARK, and flashes the ABORT softkey. You must then reinitialize the rover before proceeding.



There are essentially two ways to reinitialize the rover: by returning to a survey mark you have already occupied, or by performing one of the initialization procedures used to start a survey.

#### 4.12.1 To Return to a Previous Survey Mark

This is the procedure for reinitializing by returning to a previous survey mark. Note that you may return to *any* mark you observed successfully in the current survey; it does not have to be the last mark you surveyed before loss of lock.

1. Press the ABORT softkey.
2. Return to a mark that has already been successfully observed in this survey (not necessarily the last mark observed).
3. Position the antenna and press the STATIC softkey.

Note that you must place the antenna in the same position as when this survey mark was originally occupied, within  $\pm 5$  c m.

4. Re-enter this survey mark's point ID and wait until at least one minute passes and the ROVE softkey appears. Be sure to enter the point ID correctly; otherwise the postprocessing software will not be able to process the reinitialization data.
5. Press the ROVE softkey and proceed with the survey

#### 4.12.2 To Perform an Initialization Procedure

In principle, any of the three initialization procedures described in the earlier sections may be used to reinitialize an interrupted survey. In practice, initialization with a fixed baseline is usually the only practical choice because it is the only method that does not require the rover to return to the site of the base station.

Initialization with a fixed baseline does require the rover to go to a reference mark. If no reference mark is nearby, you may choose to create one on the spot by performing a control survey. This is very

attractive option if your rover has FastStatic capability, letting you survey a reference mark very accurately in 20 minutes or less.

You need not interrupt your kinematic survey to conduct a FastStatic observation. Simply set up the antenna, press the STATIC softkey as if you were performing a kinematic observation, and collect data for an appropriate length of time. As a rule of thumb, you should observe a minimum of:

- 8 minutes if you are confident of tracking six satellites for that period,
- 15 minutes if you are confident of tracking five satellites, and
- 20 minutes if you are confident of tracking four satellites.

During periods of marginal PDOP or doubtful satellite availability, it is prudent to run a conventional FastStatic survey and let the FastStatic status screen tell you when the observation is complete.

### 4.12.3 Delaying Reinitialization

When a rover loses lock, you are not absolutely required to reinitialize it immediately; you can continue surveying and reinitialize the rover at some later point. In general this practice is *not recommended*, because it poses the risk that you will lose lock again before you reinitialize. You will then have to repeat whatever work you have done since the first loss of lock.

There are special cases, though, in which delaying reinitialization is reasonable. For example, you might lose lock before the last survey mark in a survey; if your standard procedure calls for reinitializing at the end of the survey in any case, there may be little to lose by skipping an extra reinitialization before the last survey mark.

#### 4.12.4 Setting the Kinematic Alarm's Volume

The receiver beeps to warn you when high PDOP or loss of lock interrupts a kinematic survey. This beep is called a *kinematic alarm*, and you can control its volume from the receiver's *Modify* menu.

To set the kinematic alarm's volume, select KINEMATIC ALARM from the *Modify* menu. The receiver displays this screen:

```

KINEMATIC ALARM VOLUME:      /---  UP
      POOR PDOP ALARM [ ___ ]----- DOWN
                                /---  UP
      RETURN TO MARK ALARM [ ___ ]----- DOWN
  
```

The volume of each type of alarm is indicated by the length of the bar between the square brackets. *If the alarm is turned off, the word OFF is displayed.*

To adjust each alarm's volume, press the corresponding UP and DOWN softkeys. To turn an alarm off, press the DOWN softkey until OFF appears.

Press [ENTER] or [CL EAR] to return to the *Modify* menu

#### 4.12.5 Loss of Lock at the Base Station

Loss of lock or high PDOP at the base station is the most common cause of failure in kinematic surveys, because there is no way you can know it has happened if the base station is unattended. Therefore, you should plan the survey and set up the base station in such a way that loss of lock *can not* occur.

If any incident occurs that *might* make the base station lose lock, find out if it did by comparing the base station's number of continuous measurements to its total measurement count. If you can't find out whether the base station lost lock, assume it did.

When the base station loses lock you must reinitialize *every* rover, even if none of the rovers indicate a need to do so.

## 5 Differential GPS

---

A differential GPS base station (also called a *reference station*) operates at a known location and generates *corrections* which reflect the current errors in measurement data received from the satellites being tracked. These signals are fed through a radio modem to a transmitter. Other GPS receivers at unknown locations (the rovers, or *differential stations*) can acquire the corrections through a communications receiver and use them to compensate for the errors in the measurement data they receive. In this manner they can compute corrected position fixes in real time.

Differential GPS (DGPS) compensates for the errors introduced by Selective Availability, and to some extent for errors caused by atmospheric conditions. Its effective range is limited by the range of the radio equipment used, and by the distance over which errors observed at the base station will be meaningful at a rover. At its best, DGPS yields positions that are precise to better than  $\pm 1$  meter RMS horizontal and  $\pm 1.6$  meters RMS vertical on receivers that use Maxwell technology, and to  $\pm 2$ – $5$  meters RMS horizontal and  $\pm 3$ – $8$  meters RMS vertical on receivers that do not. It can produce useful results—with gradually decreasing precision and consistency—at ranges of up to several hundred kilometers.

Several variations are possible on the basic DGPS procedure:

- You can log measurements instead of (or in addition to) transmitting corrections by radio. This will enable a postprocessing program to compute corrected position fixes. The postprocessing programs most often used with DGPS are PostNav II and the MCORR300 utility which accompanies PFINDER.
- You can display corrected position fixes on the LCD, log them for later use, and/or transfer them to other equipment through a serial port.
- You can set up your own base station or use corrections broadcast for public use by an agency such as the United States Coast Guard.

This chapter discusses the basic DGPS procedure and several variations like the ones mentioned above.

For more detailed information about the principles behind DGPS, see the booklet *Differential GPS Explained*, listed in the *Receiver Reference's* bibliography.

A Survey Controller or Seismic Controller is a hand-held data entry and display unit that may be used to control a rover (a differential station) in DGPS operations. This chapter discusses only DGPS procedures for a receiver without a Controller. For information about doing DGPS with the aid of a controller, see the *Survey Controller Operation Manual*.

## 5.1 Equipment and Software Require

To perform DGPS operations you need the following equipment at each station:

- *Rover:* A Series 4000 receiver with the RTCM-104 Input Option.

*Base station:* A Series 4000 receiver with the RTCM-104 Output Option.

Note that the RTCM-104 Input Option is a prerequisite for the Output Option, so any receiver equipped for use as a base station may also be used as a rover.

- A GPS antenna and antenna cable. Any antenna recommended for use with Series 4000 receivers is suitable for DGPS. For permanent base stations, where the antenna will be exposed to weather indefinitely, the Compact Dome Antenna or the Permanent Reference Station L1/L2 Geodetic Antenna is recommended.
- *Rover:* A digital communications receiver, modem, and antenna.

*Base station:* A digital radio transmitter, modem, and antenna.

A radio transceiver may be used at need as a receiver or a transmitter.

The modem may be integrated with the radio, or may be a separate unit.

- Cables for connecting the radio antenna to the radio, the radio to the modem (if they are separate units), and the modem to the receiver's serial port.
- A suitable power source. Where line power is available, use an OSM2, backed up by an uninterruptible power supply if necessary. In other situations, use long-lasting batteries such as Trimble's 10 AH battery packs, which last about 15 hours per charge.

- Tripods, clamps, or other appropriate mountings for all equipment.

For a permanent base station, the antenna may be pole-mounted in an unobstructed place on the roof of a building.

The recommended software packages for postprocessing DGPS data are Post-Nav II and PFINDER. For real-time error detection and quality control, use DeltaNavQC .

## 5.2 Outlines of the Configuration Process

This section outlines the steps in configuring a set of receivers for several variations on DGPS. The next several sections describe the individual steps in more detail. To configure your receivers, choose the type of configuration you want and work through the outline; refer to the following sections whenever you need more information. If you need more information than those sections provide, consult the screen descriptions in the *Receiver Reference*.

**To generate real-time corrections.** Perform the following steps on the base station and on each rover:

1. Set the positioning elevation mask, PDOP mask, and sync time.
2. Set the reference position. (Required for a base station; optional for a rover.)

Be sure to count the corrected antenna height in the reference position's height. DGPS, unlike surveying procedures, does not have a separate antenna height parameter.

3. Disable both RTCM-104 input and output, and all other serial port data outputs as appropriate.
4. Configure one of the receiver's serial ports to the data format used by the modem and the radio transmitter (for a base station) or receiver (for a rover). (See the section How To Configure a Serial Port in Appendix A.)



5. Set up the radio and modem to transmit RTCM-104 messages (for a base station) or receive them (for a rover).
6. Enable RTCM-104 output (for a base station) or input (for a rover) on that serial port.
7. Connect the serial port to the modem. (See the section Choice of Data Cable in Appendix A.)
8. For a rover, arrange to make appropriate use of the position fixes the receiver computes. You can log them in memory, for example, or output them to some other device through another serial port.

**To log data internally for postprocessing** (with Memory Option only). Perform the following steps on the base station and on each rover:

1. Set the positioning elevation mask, PDOP mask, and sync time.
2. Disable both RTCM-104 input and output, and all other serial port data outputs as appropriate.
3. At the beginning of operations, start logging data on the receiver. At the end of operations, stop logging data.
4. After the end of operations, download the logged data to a computer for postprocessing. (See the section Downloading Logged Data in Appendix A.)

**To log data externally for postprocessing.** Perform the following steps on the base station and on each rover:

1. Set the positioning elevation mask, PDOP mask, and sync time.
2. Disable both RTCM-104 input and output, and all other serial port data outputs as appropriate.
3. Configure one of the receiver's serial ports. (See the section How To Configure a Serial Port in Appendix A.)

4. Connect that serial port to one of the computer's serial ports. (See the section Choice of Data Cable in Appendix A.)
5. At the beginning of operations, run the data logging program (LOGST) on the computer. (See the section External Data Logging in Appendix A.)
6. Start logging data on the receiver. Because the receiver is connected to a computer running LOGST, data is automatically logged to the computer's disk, not the receiver's memory. At the end of operations, stop logging data.
7. After the end of operations, download the logged data as explained in the section Downloading Logged Data in Appendix A. (Even though the logged data is already on the computer's disk, it must be “downloaded” to make it available for postprocessing.)

**To generate real-time corrections and simultaneously log data for processing.** Simply perform all of the steps required by one of the configurations you want to use, then perform any additional steps required by the other. Steps that appear in the outlines for both configurations need be performed only once.

## 5.3 Steps in the Configuration Process

The following sections discuss some other steps in the configuration process that appear in the outlines above. Some other steps, which apply to other procedures as well as to DGPS, appear in Appendix A, “Common Operations.”

### 5.3.1 Setting the Elevation and PDOP Masks and Sync Time

**What the parameters do.** The elevation and PDOP masks help to ensure that the receiver will make use of satellite signals only when they will produce accurate results.

When a satellite's elevation is less than the elevation mask, a reference or differential receiver will not use or track that satellite's signals.

When the constellation of available satellites yields a PDOP greater than the PDOP mask, a rover will not calculate position fixes. (The PDOP mask does not apply to base stations.)

The sync time determines the interval between epochs; that is, the period in which the receiver generates one set of satellite data, one correction message, or one position fix. If the sync time is 2seconds, for example, the receiver will generate one set of data every 2 seconds.

**Which parameters are used.** For computing position fixes in real time, the DGPS procedure uses parameters from the positioning parameter set. For logging satellite measurements for postprocessing, the procedure uses the quickstart or preplanned static surveying parameters. If a receiver is configured to compute position fixes and log measurements at the same time, it uses each set of parameters for the respective function.

**How to choose values.** The elevation mask is usually set between 5° and 10°, and the sync time is set between 1 and 5seconds.

An elevation mask lower than 5° is not recommended due to the high probability of noise interference. In hilly or built-up locations, a higher mask is helpful. It is generally good to set a slightly lower elevation mask on the base station than on the rovers. As a satellite rises in the sky, the base station will start logging or transmitting data for it before the rover is ready to use it; when the rover is ready, the reference data it needs will already be available.

A PDOP mask of 7 generally ensures position fixes with good precision. Position fixes calculated when the PDOP is greater than 7 are likely to be too imprecise for many applications. (As noted above, though, only a rover uses the PDOP mask.)



---

**Note** – On a base station being used to broadcast corrections for real-time use, do not set the sync time to a value that will damage the radio transmitter. See the section Sync Time and the Radio's Transmit Duty Cycle, below, for details

---

A rover is subject to no such restriction, and the sync time may be set to any value that is appropriate for the application. Bear in mind that if the rover's sync time is shorter than the base station's sync time, two or more position fixes will be calculated with the same correction data at least part of the time. If the rover's sync time is longer, some corrections will not be used at all.

Long sync times at either station tend to reduce the accuracy of position fixes. With sync times greater than 5seconds, the system's accuracy tends to be poorer than the specification's nominal levels.

**How to set the positioning parameters.** Press the [CONTROL] key. From the *Control* menu, press the MORE softkey until you see the MASKS/SYNC TIME softkey; then press that key.

The receiver displays this screen:

```
POSITIONING MASKS/SYNC TIME: |
ELEVATION MASK = +10"      | MINUS
PDOP MASK = 07.0          |
SV SYNC TIME = 001.0 SEC | ACCEPT
```

Enter the elevation mask, PDOP mask, and sync time. When you are done setting values, press the ACCEPT softkey, then the [CLEAR] key.

For more detailed instructions, see the discussion of the MASKS/SYNC TIME screen in the *Receiver Reference*.

### Sync Time and the Radio's Transmit Duty Cycle

Many digital radio transmitters are not designed for continuous transmission. Such transmitters are liable to be damaged by a sustained transmit duty cycle exceeding the recommended limit.

The transmit duty cycle depends on the sync time and the length of the data transmitted for each epoch. Therefore, you must set the sync time to a value high enough to ensure a transmission duty cycle less than or equal to the recommended limit. For example, if the transmitter's maximum recommended duty cycle is 25% and the receiver is transmitting 1 second of data per epoch, the sync time must be set to 4 seconds or more to yield a duty cycle of 25% or less.

An easy way to select a safe sync time is to measure the duration of a correction message when many SVs are visible. Your receiver is accompanied by satellite visibility software for a personal computer that can help you determine when the maximum possible number of satellites (currently 11 with typical elevation masks) will be visible.

If the radio transmitter has a "transmit" LED, you can measure the duration of a correction message by timing the LED's lighted intervals. If the communications receiver has a speaker, time the sound that the data makes when received. Varying the base station's sync rate can help you distinguish the sound of data from background noise.

Since the resulting message length is an estimate, add a reasonable safety factor (such as 1 second). Then divide by the transmitter's recommended duty cycle.

For example, if it appears to take 1 second to transmit a correction message and the transmitter's maximum transmission duty cycle is 33%, the minimum safe sync time is

$$\frac{1 \text{ second estimate} + 1 \text{ second safety factor}}{0.33} = \frac{2 \text{ seconds}}{0.33} = 6 \text{ seconds}$$

This example is intentionally conservative. More typically, a radio link with a data rate of 2400 to 48 00baud can operate with a sync time of 2 to 4 seconds. Higher data rates allow shorter sync times; lower data rates require longer ones.

You can calculate the transmission time if you know all of the data packeting schemes and timings of the modems and radios, and you use the information in the RTCM SC-104 definition to calculate the number of bits of data in each RTCM-104 message.

### 5.3.2 Setting the Receiver's Reference Position

The *reference position* is the accepted position of the receiver's antenna, expressed in the WGS-84 datum. You must ensure that it is sufficiently accurate for your application's requirements. Any error in the base station's reference position will translate directly into errors in the rovers' corrected position fixes.

Two types of reference position parameters are relevant to DGPS. The positioning reference position is used to compute position fixes in real time. The quickstart static reference position or a preplanned static reference position is used to log measurement data in quickstart or preplanned surveys, respectively

If you are using a base station to broadcast corrections in real time and simultaneously to log measurement data for postprocessing, you should set *both* types of reference position.



---

**Note** – You must change the value of the appropriate reference position parameter(s) whenever the GPS receiver antenna moves.

---

**How to set the positioning reference position.** To set the positioning reference position, press the [CONTROL] key. From the *Control* menu, press the MORE softkey until you see the REFERENCE POSITION softkey; then press that key.

The receiver displays this screen:

```
ENTER REFERENCE POSITION: | NORTH
LAT 37°23.4727805' N | SOUTH
LON 122°02.2437615' W | HERE
HGT -0007.430 m | ACCEPT
```

Enter the antenna's accepted WGS-84 coordinates, using the softkeys to change the sense of LAT (north/south), LON (east/west) and HGT (plus/minus). When you are done, press the ACCEPT softkey, then the [Cl EAR] key.

You may enter height relative to the ellipsoid (HAE) or mean sea level (MSL). A softkey for choosing the height reference appears when the cursor is in the HGT field.

**How to set the quickstart session's reference position.** When you start data logging through the *Log Data* menu's QUICK-STARTNOW! selection, the most recent position fix is logged as the reference position.

For more information, see the section Running a Quickstart Survey in Chapter 2.

**How to set a preplanned session's reference position.** When you define the session description that you will use to start the DGPS session, the session definition procedure will prompt you for a reference position. For more detailed information see the section Step 2: Enter the Station's Reference Position in Chapter 2.

You can correct a quickstart or preplanned session's reference position when you run the postprocessing program, if necessary, to improve the accuracy of the results.

### 5.3.3 Disabling RTCM-104 Input and Output and Other Outputs

You should confirm that all of the receiver's serial ports are disabled before you reconfigure ports. This will prevent several types of problems that otherwise could occur:

- If the receiver is being configured to compute corrected positions in real time, it could transmit unnecessary data on the radio link. On a base station this could delay transmission of corrections. On a rover it could interfere with reception of corrections by tying up a transceiver with transmissions when it should be receiving. In either case it could damage the radio transmitter by exceeding its transmit duty cycle.
- If the receiver is being configured to log data without real-time corrections, a rover will not log data if RTCM-104 input is disabled, because no corrections are being received. In any case, it is good practice to disable unnecessary inputs and outputs to avoid possible side effects and future problems.

For more detailed instructions, see the discussion of how to configure RTCM-104 output in the *Receiver Reference*.

**Relationship between input and output.** The receiver will not let RTCM-104 input and output be enabled simultaneously. Therefore, if you find that input is enabled you may assume that output is disabled, and *vice versa*. After disabling input you need not check output, and *vice versa*.

**RTCM-104 input.** Press the [CONTROL] key. From the *Control* menu, press the MORE softkey until you see the RTCM-104 INPUT softkey; then press that key.



The receiver displays the first of three DIFFERENTIAL STATION screens:

```

DIFFERENTIAL STATION          <-- MORE
RTCM-104 INPUTS [ OFF ] <-- CHANGE
  PORT SELECT [ OFF ] <-- CHANGE
    FORMAT [ VERSION 2 ] <-- CHANGE
  
```

Press the RTCM-104 INPUTS... CHANGE softkey to display OFF.

Press the [Cl EAR] key twice to return to the status display

**RTCM-104 output.** Press the [CONTROL ] key. From the *Control* menu, press the MORE softkey until you see the RTCM-104 OUTPUT softkey; then press that key.

The receiver displays the first of three RTCM-104 REFERENCE STATION screens:

```

RTCM-104 REFERENCE STATION    <-  MORE
  ENABLE [ PORT 1 ] <-  CHANGE
  STATION ID [ 0000 ] <-  CHANGE
    FORMAT [ VERSION 2 ] <-  CHANGE
  
```

Press the ENABLE... CHANGE softkey to display OFF.

Press the [Cl EAR] key twice to return to the status display

**Other types of output.** You should also disable any other types of receiver output that are enabled. Depending on what options your receiver has, you may have to disable the following types of output:

- NMEA-0183
- Cycle printouts
- 1 pulse/second time tags

Consult the *Receiver Reference* for information on controlling these types of output.

### 5.3.4 Configuring a Serial Port

For information about configuring a serial port, see the section How To Configure a Serial Port in Appendix A.

### 5.3.5 Enabling RTCM-104 Input or Output

**Relationship between enabling and disabling.** The procedures for enabling input and output are essentially the same as the procedures for disabling them, as described in the section Disabling RTCM-104 Input and Output and Other Outputs. You must set the INPUTS or OUTPUTS parameter to the number of the serial port you are using, and you must set the other input/output parameters as well.

**RTCM-104 input.** Press the [CONTROL] key. From the *Control* menu, press the MORE softkey until you see the RTCM-104 INPUT softkey; then press that key.

The receiver displays the first of three DIFFERENTIAL STATION screens:

```

DIFFERENTIAL STATION      <-- MORE
RTCM-104 INPUTS [ OFF ] <-- CHANGE
   PORT SELECT [ OFF ] <-- CHANGE
   FORMAT [ VERSION 2 ] <-- CHANGE
  
```

Press the RTCM-104 INPUTS... CHANGE softkey to display ON (to let the receiver operate in differential mode only) or ON/AUT (to let it fall back to autonomous operation when it cannot operate in differential mode). Go on to set the rest of the parameters.

Press the PORT SELEC ... CHANGE softkey until the port number displayed is that of the serial port you want connected to the modem.

Be sure that FORMAT is set to the version of RTCM-104 being generated by the base station whose corrections will be used. If you control the base station, Trimble suggests that you use Version 2.0. Press the appropriate CHANGE softkey, if necessary, to change the format.

Press the MORE softkey to display the next screen:

```

DIFFERENTIAL STATION      <-- MORE
ASCII PRINTOUT [ OFF ] <-- CHANGE
      BEEPER [ OFF ] <-- CHANGE
STATION SELECT [ ANY ] <-- CHANGE

```

Be sure that all three parameters are set to appropriate values. Use the ones shown above if you have no reason to select others. Press the appropriate CHANGE softkey(s) to change the parameter settings.

Press the MORE softkey to display the next screen:

```

DIFFERENTIAL STATION      <-- MORE
      AGE LIMIT [100 SECONDS] <-- CHANGE

```

AGE LIMIT is the length of time a DGPS correction will be considered good. If the flow of corrections from the base station is interrupted, the rover will continue to use the last correction received for this length of time. Use the value shown above unless you have a reason to prefer another. Press the CHANGE softkey to change the parameter setting.

Press the [CLEAR] key twice to return to the status display

**RTCM-104 output.** Press the [CONTROL] key. From the *Control* menu, press the MORE softkey until you see the RTCM-104 OUTPUT softkey; then press that softkey.

The receiver displays the first of three RTCM-104 REFERENCE STATION screens:

```

RTCM-104 REFERENCE STATION    <-  MORE
      ENABLE [  PORT 1    ] <-  CHANGE
      STATION ID [  0000  ] <-  CHANGE
      FORMAT [ VERSION 2 ] <-  CHANGE
  
```

Press the ENABLE... CHANGE softkey to display the serial port that is connected to the modem. Go on to set the rest of the parameters.

You may leave STATION ID at 0000. Set FORMAT to the version of RTCM-104 the receiver must generate. If you have control of the rovers that will be using the generated corrections, Trimble suggests that you use Version 2.0. Press the appropriate CHANGE softkey(s), if necessary, to change the parameter settings.

Press the MORE softkey to display the next screen:

```

RTCM-104 REFERENCE STATION    <-  MORE
      PRINTOUT [  OFF    ] <-  CHANGE
      CTS->XMT DELAY [  0.0 SEC ] <-  CHANGE
      TYPE 16 MESSAGE [  OFF  ] <-  CHANGE
  
```

The defaults shown are good for general use. Press the appropriate CHANGE softkey(s) to change them if necessary.

Press the MORE softkey to display the next screen:

```

RTCM-104 REFERENCE STATION    <-  MORE
      CARRIAGE RETURN [  ON    ] <-  CHANGE
      RTCM_BIT_RATE [  OFF  ] <-  CHANGE
      MESSAGE SCHEDULE [  DEFAULT ] <-  CHANGE
  
```

The defaults shown are good for general use. Press the appropriate CHANGE softkey(s) to change them if necessary.

Press the [Cl EAR] key twice to return to the status display

### 5.3.6 Setting Up the Modem and Radio

To generate position fixes in real time, the base station must be connected to a radio modem and radio transmitter; each rover must be connected to a radio modem and communications receiver. Since many different types of radios and modems may be used, no specific instructions are given here.

Radio equipment comes in two common forms: a single device incorporating radio and modem, and a separate modem and radio, which may come from different manufacturers. Separate modems and radios may require adjustment to work together.

The Trimble TRIMTALK 900™ transceiver may be used for short-range DGPS operations, although it is designed primarily for RTK surveying. It operates in the 902-928MHz band, and is certified for unlicensed operation in the U.S. and some other countries. For more information, see the *TRIMTALK 900 Operation Manual*.

Trimble can supply or recommend other appropriate equipment for your specific application.

**Mounting the antenna.** Mount each station's radio antenna in as high a location as possible, with as clear a line of sight to the other station as possible. To minimize interference problems, try to mount each radio antenna away from its GPS receiver's GPS antenna. Shipboard installations sometimes deal with interference by mounting the GPS antenna above any transmitting antenna.

### 5.3.7 Connecting the Serial Port to the Other Device

Use an appropriate data cable to connect the serial port you have configured to the computer, modem, or other device. For details, see the section Choice of Data Cable in Appendix A.

### 5.3.8 Running the Data Logging Program (Only with Memory Option)

The procedure for running the data logging program is described in the section External Data Logging in Appendix A.

### 5.3.9 Starting Data Logging (Only with Memory Option)

The DGPS procedure can log either or both of two types of data: satellite measurement data and corrected position fixes.

**To log data for postprocessing only.** You must log satellite measurement data on both the base station and the rover. Configure both of them to log data NORMALLY.

**To log position fixes only.** Configure the rover to log data EXCLUSIVELY. Configure the base station to log no data at all.

**To log both types of data.** Configure the rover to log data EVERY CYCLE. Configure the base station to log data NORMALLY.

**How to configure a quickstart data logging session.** The procedure is the same as for running a quickstart static survey. See the section Running a Quickstart Survey in Chapter 2. On QUICKSTART CONTROLS screen, set the STORE POSITION parameter to the appropriate value: NORMALLY, EXCLUSIVELY, or EVERY CYCLE.

**How to configure a preplanned data logging session.** The procedure is the same as for defining and running a preplanned static survey. See the sections Defining a Preplanned Static Survey and Running a Preplanned Survey in Chapter 2. On SESSION SPECIAL CONTROLS screen, set the POSITION LOGGED parameter to the appropriate value.

**How to configure a station to log no data at all.** Simply omit the steps for starting either a quickstart or preplanned data logging session. The settings of the STORE POSITION and POSITION LOGGED parameters do not matter.

## 5.4 What Is Different During Data Loggin

**Main Status screen.** The receiver displays a screen like this one in place of the *Status* screen that appears in positioning mode:

```

0492-137-0 LOGGING FOR 0:01 | ELEV/AZM
APPROX. MEMORY LEFT: 94 HR | POSITION
SV02,19,06,18 | DATE
PWR2+[_____]IP* 2:05:03 PST/24 | MORE

```

This screen is similar to the positioning mode *Status* screen except for the first two lines, which show the name of the data file, the number of hours and minutes data logging has been under way, and the approximate amount of data logging time left before memory is full. The ELEV/AZM, POSITION, and DATE softkeys have their usual functions.

The MORE softkey leads to a series of three other screens that describe the status of data logging, the satellites being tracked, and some important operating parameters (chiefly the elevation mask and sync time). These screens are shown and explained in the section Performing Other Operations During a Static Survey in Chapter 2.

**Log Data screen.** The [ F10 ] key displays this menu:

```
SURVEY:                                | USER INPUT  
                                         |   CHANGES  
                                         |  
                                         | END SURVEY
```

The USER INPUT and CHANGES softkeys let you enter user input (e.g., field notes) and change the antenna parameters and data file name. They work just like the corresponding softkeys that appear just before you start logging data.

The END SURVEY softkey, described in the next section, terminates data logging.

**Position calculations.** A DGPS base station does not compute positions. Its position is fixed at its reference position. The POSITION screen will display the reference position, and cycle printouts that include position will present the reference position.

## 5.5 Stopping Data Logging

To stop logging data, press the [ F10 ] key to display the SURVEY menu, shown above. Then press the END SURVEY softkey. The receiver displays this screen:

```
STOP THE CURRENT SURVEY ?             | YES  
                                         |  
                                         | NO
```



Select YES. The receiver stops logging data and briefly displays the this screen:

```
SURVEY ENDED -- GET READY TO INPUT
ANTENNA HEIGHT
```

If you have not previously entered the antenna parameters, the receiver now prompts you to do so. Enter appropriate values as described in the section Entering Antenna Parameters in Appendix A. When you are done, the receiver returns to the regular *Status* screen.

If you are doing external data logging, LOGST automatically stops running and returns control to DOS when you stop the survey. *Do not* stop LOGST by turning the computer off or restarting it. If you do that, you may lose some or all of the data that has already been logged.

**Conditions that terminate data logging.** The following unusual conditions also terminate data logging:

- Filling all of the receiver's memory with data.
- A power failure.
- Any condition that reduces the number of available satellites below the minimum required to generate position fixes, given the receiver's current parameter settings.

**How to restart data logging.** You can restart a data logging session after correcting one of these conditions (or after you have stopped it manually). If you are doing external data logging, remember to restart LOGST before you restart data logging.

When you restart an internal data logging session, the receiver logs data to a new file with the same name as the session's earlier file(s). You can distinguish the different files by their times of creation.

When you restart an external data logging session, you should specify the same file name as for the session's earlier file(s). LOGST assigns the new file a different extension to make the name unique.

At the end of the data logging session, you will have two or more files representing different parts of the session. To construct a record of the entire session, you must download all of these files and merge them. See the section How the Receiver and Programs Handle File Names in Appendix A for details.

If a preplanned data logging session is scheduled to be running when the receiver is powered on again after a power failure, the receiver will automatically restart it (or start it, if it was not running yet when the failure occurred). If the survey is restarted, the SURVEY RESTARTED display will appear. You then must cancel the operation manually by pressing the [LOG][DATA] key and selecting END SURVEY.

Similarly, if a quickstart data logging session was running when power failed, the receiver will attempt to restart it the next time it is powered on. You should respond the same way as for a preplanned session.

## 5.6 Downloading Logged Data

The procedure for downloading logged data is described in the section External Data Logging in Appendix A.

## 5.7 Making Use of Position Data

If you set up the receiver to correct position fixes in real time, you must make some provision for using those position fixes, and any other data the receiver produces that is useful to you.

**Display it on the LCD** The simplest alternative is to display position fixes on the receiver's LCD. The *Status* menu's POSITION screen gives a continuous display of the current position fix. To see this screen, simply press the [CLEAR] key repeatedly until the display stops changing, then press the POSITION softkey.

**Log it in memory.** If your receiver has the Memory Option, you can log position fixes in memory; see the section Set Special Controls in Chapter 2. Then download them to a computer; see the section Downloading Logged Data in Appendix A. You can extract the position fixes from the data file with a postprocessing program such as Post-Nav II, and store them in a data file for use by a spread sheet, word processor, etc.

**Send it to another device.** Many specialized devices can use position data from a receiver for navigation, vessel stabilization, and other purposes. One such device is the Trimble EchoXL Remote Display, which displays coordinates, course information, and other data.

To send position data to such a device, you must configure one of the receiver's serial ports and connect the port to the device, as explained in the section Connecting a Serial Port to Another Device in Appendix A. Then you must enable one of the receiver's cycle printouts and direct it to the serial port. (A cycle printout is any type of output that the receiver generates once per measurement cycle.)

For information about enabling cycle printouts, see the section Enabling Cycle Printouts in Appendix A.

When you connect a device to a Series 4000 receiver, you may have to set the REMOTE INTERFACE PROTOCOL parameter to make the receiver and the other device communicate correctly. For information about this parameter, see the section How to Use a Remote Protocol in Appendix A.



## 6 Navigation

---

Series 4000 receivers can be used for navigation with or without the Navigation Package Option. The Navigation Package Option adds several useful features, though; the most notable is the ability to store definitions of up to 99 waypoints and define a course that traverses any set of waypoints in any order.

The navigation functions use corrected positions if the RTCM-104 Input Option is operating, and use RTK position fixes if RTK is operating. Otherwise they use uncorrected positions; that is, the receiver operates autonomously. The accuracy of the navigation displays reflects the accuracy of the positioning procedure being used.

The precision of the position fixes depends primarily on how they are computed. If the receiver is computing corrected position fixes with DGPS, as described in Chapter 5, it yields fixes that are precise to  $\pm 2$ – $5$  meters RMS, or to better than 1 meter RMS for a Maxwell-based receiver. If it is computing position fixes with RTK, the fixes are precise to about  $\pm 2$  cm + 2 ppm. In any other case the receiver computes uncorrected (autonomous) position fixes, yielding fixes that are precise to about  $\pm 100$  meters horizontal RMS if Selective Availability is active, and about  $\pm 10$  to 20 meters RMS if it is not.

The precision of velocity readings is about 0.1 knots when the receiver is computing uncorrected position fixes, regardless of whether Selective Availability is active or not. With DGPS or RTK, it is higher.

## 6.1 Displaying Your Positio

To display your current position, go to the *Status* screen and press the POSITION softkey. The receiver will display a screen similar to this one:

```
LAT: 37°23.6410' N    PDOP: 2.9|NAVIGATE
LON: 122°02.2318' W    HDOP: 1.8|VELOCITY
HGT: -0001.0 m (MSL)   VDOP: 2.3|RTCM-104
                        TDOP: 1.6|  STATS
```

**The left part of the display.** The first three lines show your current latitude, longitude, and height.

On the HGT line, MSL means “mean sea level”; if nothing appears in this space, the height is relative to the WGS-84 reference ellipsoid.

The last line shows the type of position fixes being displayed. This depends on the number of satellites the receiver is tracking, and on whether the receiver is configured to compute corrected (DGPS) positions.

- DIFFERENTIAL: Current, corrected 3D positions.
- DIFF/FIXED HEIGH : Current, corrected 2D positions.
- DIFF/FIXED LAT/LON: Current, corrected 1D (height-only) positions.
- OLD POSITION: An old, corrected position. The receiver displays this when it is configured to compute corrected position fixes, but cannot do so because it is not receiving valid RTCM-104 corrections. The screen shows the most recent corrected position fix.
- Blank: Uncorrected 3D positions.
- FIXED LAT/LON: Uncorrected 2D positions.
- FIXED HEIGH : Uncorrected 1D positions.

The receiver computes 2D positions by using the height from the last computed value, or the height from the reference position if LAT and LON are non-zero. It computes 1D positions by assuming that LAT and LON have the last computed values, or the values from the reference position if it is non-zero.

**The middle of the display: DOPs.** The middle part of the display shows several Dilution of Precision (DOP) metrics, which reflect the amount of error introduced into the position fix by the geometry of the satellites currently being tracked. The metrics are position DOP (PDOP), a measure of error in three dimensions; HDOP, the horizontal component of PDOP; VDOP, the vertical component of PDOP; and time DOP (TDOP), a measure of error in the receiver's clock relative to GPS time.

PDOP is the best overall measure of the quality of a position fix. In general, a PDOP below 4.0 indicates an excellent position fix; a PDOP above 7.0 indicates a position fix that is too poor to be useful for most purposes.

**The middle of the display: statistics** (only with QA/QC Option). Press the STATS softkey to display statistics instead of DOPs in the middle of the screen:

```
LAT: 37°23.4586' N      SIGMA N:23.9m
LON:122°02.2737' W      SIGMA E:12.5m
HGT: -0016.3 m (MSL)    SIGMA U:51.2m
                        UNIT: 0.86 DOPS
```

Each SIGMA is the square root of the error covariance matrix term representing error in one coordinate: latitude (N), longitude (E), and height (U). Sigma values are computed using the constellation geometry and the error estimate for each satellite. They are expressed in meters.

UNIT is an *a posteriori* estimate of the relationship of the sigma values to the actual error. It is computed only for overdetermined solutions, *i.e.*, when more satellites are used than are necessary for the type of solution being computed.

- UNIT = 1.0: The sigma values roughly correspond to the actual errors.
- UNIT > 1.0: The sigma values probably overestimate the actual errors.
- UNIT < 1.0: The sigma values probably underestimate the actual errors.

**Local datum or local zone display selected.** If the receiver is configured to display positions in the local datum or local zone (see the section Using Local Datums and Projections in Appendix A), the position screen resembles one of these:

```
LAT: 37°23.6410' N   PDOP: 2.2|NAVIGATE
LON: 122°02.2318' W   HDOP: 1.8|VELOCITY
HGT: -0001.0 m (MSL) VDOP: 2.3|RTCM-104
                        NAD 83 |   STATS
```

```
NORTH:+0600050.224 m PDOP: 2.2|NAVIGATE
EAST :+1863807.380 m HDOP: 1.8|VELOCITY
HGT: -0001.0 m (MSL) VDOP: 2.3|RTCM-104
                        CA3   |   STATS
```

The last line displays the short name of the local datum or local zone. For the local datum, LAT, LON, and HGT display the position in the local datum.



For the local zone, NORTH, EAST, and HGT display the position as a northing and easting in the local zone, and a height in the local datum. If the receiver determines that the current position is not within the local zone, it displays the message 'CHECK ZONE' instead of a northing and easting.

**To change elevation mask and PDOP mask.** The positioning elevation mask specifies an elevation below which satellites will not be used to compute position fixes. The PDOP mask specifies a PDOP value above which the receiver will not compute position fixes at all. For information about how to change these parameters, see the section Setting the Elevation and PDOP Masks and Sync Time in Chapter 5.

**To change the format of the coordinates.** Press [MODIFY] and select UNITS OF MEASURE from the *Modify* menu. You can set the format to either degrees/minutes/decimals, or in degrees/minutes/seconds/decimals.

**To change the height reference.** Press [MODIFY] and select ALTITUDE REFERENCE from the *Modify* menu. You may set the altitude reference to the WGS-84 ellipsoid or mean sea level by pressing the CHANGE softkey until M.S.L. or ELLIPSOID appears.

## 6.2 Using the Navigation Screens

The navigation screens can be used to steer a vehicle from one location to another by defining and following a course consisting of some number of straight lines (legs).

These screens appear in two versions: a basic version on receivers without the Navigation Package Option, and a more extensive version on receivers with that option.

### 6.2.1 NAVIGATE without Navigation Package Option

On receivers that do not have the Navigation Package Option, the NAVIGATION screens let you define a destination, called a *waypoint*, and display information about your position relative to the waypoint as you travel toward it.

To display the main NAVIGATION screen, press the [STATUS] key; from the main *Status* screen, select POSITION, then NAVIGATE. The receiver will display this screen:

```

    BEARING: 181° TRUE      |WAYPOINT
      RANGE:      228 m    |
HEAD SOUTH:      2 m     |
    & EAST:      228 m    |   UNITS
  
```

The screen shows the waypoint's bearing and range from your current position, and the north/south and east/west components of its range.

**To view and change the waypoint's coordinates.** Select WAYPOINT. The receiver will display this screen:

```

ENTER DESTINATION WAYPOINT: | NORTH
LAT  37°23.3448' N         | SOUTH
LON  122°02.2487' W         |  HERE
                               | ACCEPT
  
```

Enter the waypoint's coordinates. To change a coordinate's direction, press the NORTH and SOUTH or EAST and WEST softkeys (depending on which field the cursor is in). Press ACCEPT to accept the waypoint coordinates and return to the main NAVIGATE screen.

To set the waypoint to the receiver's current position, select HERE, then ACCEPT. This is useful if you will need to return to your current position from another, possibly unknown place.

Remember that if the receiver is computing uncorrected position fixes and Selective Availability is active, the current horizontal position is precise to about 100 meters RMS. In the worst case, when the errors at the start and end of your round trip are cumulative, you may return to a point about 200 meters away from your origin.

**To change the units of distance.** Press the main NAVIGATION screen's UNITS softkey to cycle through the available units of distance: miles (mi), nautical miles (nm), meters (m), and feet (ft). When the units are meters, large values are displayed in kilometers (km).

### 6.2.2 NAVIGATE with Navigation Package Option

On receivers that have the Navigation Package Option, the NAVIGATION screens let you define and use up to 99 *waypoints*, numbered from 01 to 99. A waypoint is a position which represents the beginning or end of a course, or an intermediate point on a course. The part of a course between two waypoints is called a *leg* or *leg line*.

You can follow a complex course by entering an appropriate set of waypoints, then selecting the leg lines that trace out the course, one after another, as you proceed. When you select each leg line, the receiver displays information about your position relative to the waypoint at its end.

#### How to Plan Courses and Waypoints

Navigation with waypoints is a two-step process:

1. Define an appropriate set of waypoints.
2. To navigate a course, select its first leg line and navigate from your origin to the first waypoint. Then select the second leg line and navigate from the first waypoint to the second one, and so on until you reach your destination.

There are two approaches to defining and using waypoints.

First, you can define a sequence of consecutively numbered waypoints that trace out a course when selected in ascending or descending order. This approach makes navigation very easy; you only need to remember which waypoint starts each course, then select leg lines that run from one waypoint to the next until you reach your destination.

Figure 6-1 illustrates this approach. It shows a group of waypoints that define two courses; one is traced by waypoints 1 through 5, the other by waypoints 11 through 15. Notice that in three cases, more than one waypoint describes the same position; that is a natural consequence of using this approach.

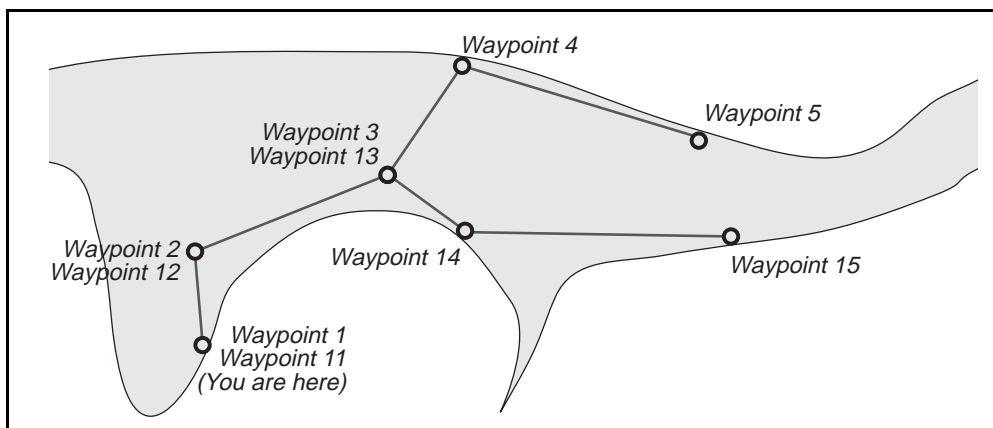

**Figure 6-1. Sequences of Waypoints Defining Courses**

Second, you can define a network of waypoints for all of the origins and destinations of interest to you, and all of the intermediate points that the courses among them require. This approach is extremely flexible; a hundred properly defined waypoints may allow you to navigate thousands of different courses. The disadvantage of this approach is that you must select leg lines with care; most people find it difficult to remember courses defined by sequences of waypoints that do not go in order.

Figure 6-2 illustrates this approach. You can navigate a reasonably direct route between many different pairs of points by following an appropriate sequence of legs. For example, you can go from waypoint 11 to waypoint 22 via waypoints 1, 2, and 21; you can go from waypoint 11 to waypoint 13 via waypoints 1, 2, and 12.

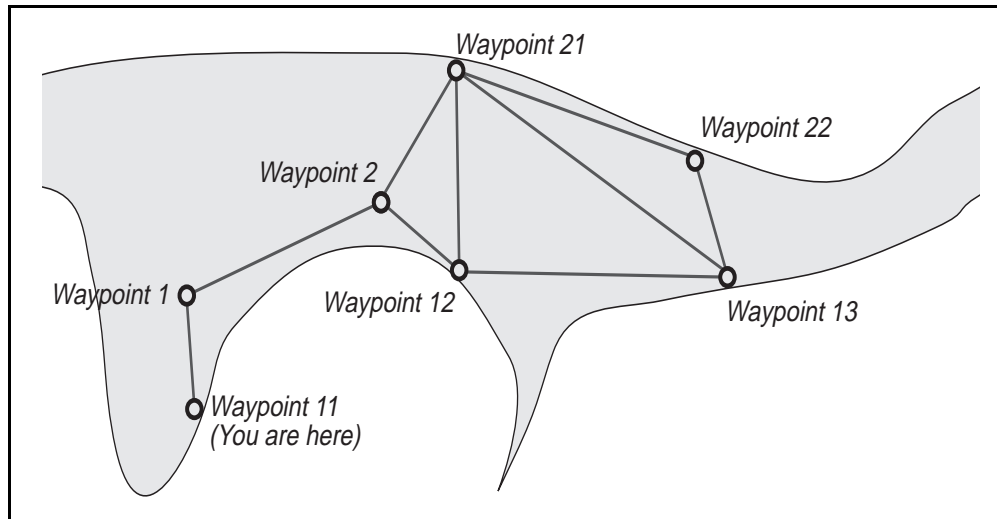

**Figure 6-2. A Network of Waypoints Defining Courses**

### How to Use the Main NAVIGATION Screen

**To display.** Press the [STATUS] key. From the main *Status* screen, select POSITION, then NAVIGATE. The receiver will display a screen that resembles one of these:

FROM: 00	TO: 01		SELECT LEG
BEARING:	181° TRUE		CHANGE FORMAT
RANGE:	228 m		EDIT WAYPNTS
XTE:	2 m LEFT		SET UNITS

```

FROM: 00 TO: 01 | SELECT LEG
RNG/BRG: 248 m 182° | CHANGE FORMAT
SOUTH: 248 m | EDIT WAYPTS
WEST: 11 m | SET UNITS

```

```

FROM: 00 TO: 01 | SELECT LEG
BEARING: 183° TRUE | CHANGE FORMAT
RANGE: 253 m | EDIT WAYPTS
STEER: >>>>>>*<----- | SET UNITS

```

**To read.** Each version of the screen displays the waypoint numbers that define a leg line. All of the examples above show the leg line that goes from waypoint t0 to waypoint t1.

The first screen displays the *to* waypoint's range and bearing, and your *cross-track error*; that is, your current position's distance left or right of the leg line.

The second screen displays the *to* waypoint's range and bearing, and the north/south and east/west components of the range.

The third screen displays the *to* waypoint's range and bearing, and an “arrow” that indicates the direction to steer to intersect the leg from the current position. The number of arrowheads represents the distance from the current position to the nearest point on the course. The distance that each arrowhead represents is adjustable.

**To change the display's format.** Press the CHANGE FORMAT softkey. If you leave the NAVIGATION screens, the format you select will reappear whenever you return to them.

### How to Change Units of Distance

To display the screen for changing the units of distance used in the main NAVIGATION screen, press the SET UNITS softkey. The receiver displays a screen like this one:

```

RANGE UNITS = METERS      <-- CHANGE
XTE ARROWS = [000025] m  <-- CHANGE
                           PREVIOUS
  
```

To change the units of distance, press the RANGE UNITS... CHANGE softkey. The display will cycle through the available units: miles (mi), nautical miles (nm), meters (m), and feet (ft). When the units are meters, large values are displayed in kilometers (km).

**To change the scale of the cross-track error arrows.** Press the XTE ARROWS... CHANGE softkey. The receiver will display a screen like this one:

```

RANGE UNITS = METERS      |
XTE ARROWS = [000025] m  |
                           |
                           | ACCEPT
  
```

In this example, the screen shows that each arrowhead in the XTE display represents a cross-track error of 25meters. To change the scale of the XTE arrows, enter a new value and press ACCEP .

Note that scale of XTE ARROWS is expressed in meters when the range units are metric, and in feet when the range units are English.

**To return to the main NAVIGATION screen.** You may press the [ENTER] key or the PREVIOUS softkey.

## How to Display and Set Waypoints

From the main NAVIGATE screen, select EDIT WAYPNTS. The receiver displays a screen like this one:

```
SELECT WAYPOINT -> 01      |      NEXT
LAT   37°23.3448' N      |      PREVIOUS
LON   122°02.2487' W      |
                             |
```

The screen shows the waypoint number and the coordinates of that waypoint.

**To select a different waypoint.** You can select a waypoint by pressing the NEXT and PREV softkeys. These keys increment and decrement the waypoint number and display the corresponding set of coordinates.

You can also select a waypoint by entering its number through the keypad. When you enter the second digit of the number, the receiver displays the screen shown below, and shows the corresponding set of coordinates.

```
EDIT WAYPOINT -> 01      |      HERE
LAT   37°23.3448' N      |      DELETE
LON   122°02.2487' W      |      SOUTH
                             |      ACCEPT
```

**To change the selected waypoint's coordinates.** If the receiver is still displaying the first screen shown above, press [ENTER] to display the second screen. Note that the cursor moves to the start of the LAT field.

Enter the latitude of the waypoint, then the longitude. You may use the NORTH/SOUTH/EAST/WEST softkey to toggle the direction of whichever coordinate you are entering. Press [ENTER] to accept the latitude and move the cursor on to the LON field; press [ENTER] or



ACCEPT to accept the longitude and return to the first screen shown above.

You may now select another waypoint or press [CLEAR] to return to the NAVIGATE screen.

**To clear the selected waypoint's coordinates.** Press [ENTER], then select DELETE. This sets the waypoint's coordinates to 00°00' latitude and 000°00' longitude.

**To set the selected waypoint's coordinates to the receiver's current location.** Press [ENTER], then select HERE. This is useful if you will need to return to your current position from another, possibly unknown place.

**An example.** Suppose you want to set coordinates for waypoints 1, 2, 3, and 4 to define one of the courses shown in Figure 6-1. You should:

1. Press [STATUS], then select POSITION, then NAVIGATE, then EDIT WAYPOINTS.
2. Press [0] [1] to display waypoint 1. Press [ENTER] to display the screen for setting coordinates.
3. Press the HERE softkey to set the waypoint's coordinates to your current position.
4. Press NEXT to display waypoint 2. Press [ENTER] to redisplay the screen for setting coordinates. Enter the waypoint's latitude and press [ENTER], then enter its longitude and press [ENTER] again (or press ACCEPT).
5. Repeat step 4 to display and set waypoint 3.
6. Repeat step 4 again to display and set waypoint 4.
7. Repeat step 4 again to display and set waypoint 5.
8. Press [CLEAR] to return to the main NAVIGATION display.

### How to Select a Leg Line

The leg line that the main NAVIGATION screen displays is called the *selected leg line*.

To select a different leg line, press the SELECT LEG softkey. The receiver displays a screen similar to this one:



This screen identifies the currently selected leg line by the numbers of its *from* and *to* waypoints. The example above shows that the selected leg line runs from waypoint 0 to waypoint 1.

**To select a leg line with the softkeys.** Press the NEXT and PREV softkeys to display the desired leg line, then press ACCEPT.

NEXT copies the *to* waypoint number to *from*, then increments *to* by one.

PREV copies the *from* waypoint number to *to*, then decrements *from* by 1.

For example, suppose the selected leg line runs from waypoint 5 to waypoint 10.

- Pressing NEXT three times would select the leg line that runs from waypoint 10 to 11, then from 11 to 12, then from 12 to 13.
- Pressing PREV three times would select the leg line that runs from waypoint 4 to 5, then from 3 to 4, then from 2 to 3.

NEXT and PREV are most useful if you define waypoints that trace out a course when taken in ascending or descending order.

**To select a leg line with the keypad.** Enter waypoint numbers in the FROM and TO fields, then press the ACCEPT softkey.

For example, to select the leg line that runs from waypoint 00 to waypoint 21, press [0] [0] [2] [1] and ACCEP .

*Note that the receiver treats FROM and TO like a single field with some unchangeable characters in the middle.* To enter values in FROM and TO, simply press four numeral keys. Do not press [ENTER] or [CLEAR], or the receiver will return to the main NAVIGATION screen. To move back and forth between FROM and TO, use the [<] and [>] keys.

Entering waypoint numbers through the keypad is useful if you are following a course that does not follow an ascending or descending sequence of waypoints.

**An example using a sequence of waypoints.** To navigate the course defined by waypoints 1 through 5 (defined in the preceding section):

1. From the main NAVIGATION screen, press the SELECT LEG softkey.
2. Press [0] [1] [0] [2] to select the leg that runs from waypoint 1 to waypoint 2 . Press theACCEPT softkey to select the leg and return to the main NAVIGATION screen.
3. Navigate from your origin (waypoint 1) to waypoint 2.
4. Press the SELECT LEG softkey again, then the NEXT softkey, to select the leg that runs from waypoint 2 to waypoint 3. Press ACCEPT. Navigate the leg line.
5. Repeat step 4 to select and navigate the leg line that runs from waypoint 3 to waypoint 4.
6. Repeat step 4 again to select and navigate the leg line that runs from waypoint 4 to waypoint 5.

**An example using a network of waypoints.** To navigate the course defined in Figure 6-2 by waypoints 11, 1, 2, 12, and 13:

1. From the main NAVIGATION screen, press the SELECT LEG softkey; then press [1] [1] [0] [1] to select the leg that runs from

- waypoint 1 1 to waypoint1. Press the ACCEPT softkey to select the leg and return to the main NAVIGATION screen.
2. Navigate from your origin (waypoint t11) to waypoi nt1.
  3. Press the SELECT LEG softkey again, then the NEXT softkey, to select the leg that runs from waypo int1 to waypoi nt2. Press ACCEPT. Navigate the leg line.
  4. Press the SELECT LEG softkey again, then the NEXT softkey, to select the leg that runs from waypoint 2 to waypoint 3. Press [>] [>] to move the cursor to the beginning of the *to* waypoint number; press [1] [2] to change the *to* waypoint number fro 2 to 12. Press ACCEPT. Navigate the leg line.
  5. Repeat step 3 to select and navigate the leg line that runs from waypoint 12 to waypoint 13.
  6. Repeat step 3 again to select and navigate the leg line that runs from waypoint 13 to waypoint 14.

### 6.3 Displaying Your Velocity

To display the receiver's current velocity, press the [STATUS] key. From the main *Status* display, select POSITION, then VELOCITY. The receiver will display a screen similar to this one:

```
VELOCITY:          | UNITS
HORIZONTAL:   0.78 km/h @ 146° | POSITION
VERTICAL:    +0.09 km/h      |
                               |
```

The screen shows the horizontal and vertical components of the receiver's current velocity. The bearing of the horizontal component is shown relative to true north.

**To change the units of velocity.** Press the UNITS softkey to cycle through the available units: miles/hour horizontal and vertical; kilometers/hour horizontal and vertical; meters/second horizontal and vertical; knots horizontal, feet/minute vertical; and knots horizontal and vertical.

**To leave the screen.** Select POSITION to return to the POSITION screen (one level up). Press [Cl EAR] to return directly to the main *Status* screen (two levels up).



# 7 GIS Data Acquisition

---

GIS data acquisition consists of using GPS equipment to record positions and descriptions of objects, and to place the data in a geographic information system (GIS)—a database management system for the capture, storage, analysis, and display of spatial data.

Some typical applications of GIS data acquisition are:

- Maintaining an inventory of assets such as road signs, utility poles, or pipelines.
- Collecting information about the species and health of a particular area's trees.
- Collecting data about traffic accidents.

A typical GIS data acquisition project has three stages:

- **Planning.** In this stage you not only decide what information to collect and where to find it; you also decide how to structure the information in the database, and design the database if necessary. Trimble software can produce a data dictionary from your database definition; you can download the data dictionary to an Asset Surveyor and use it to automate much of the task of entering and validating data.
- **Data collection.** In this stage you use Series 4000 receivers, Asset Surveyors, and other tools to acquire the data you need.
- **Data analysis.** In this stage you upload the collected data to a computer, add it to the GIS database, and use it.

This chapter provides a brief introduction to the concepts of GIS data acquisition. It does not discuss GIS data-acquisition procedures in detail because they are covered fully in the *GIS Surveyor System Overview*. See the bibliography in the *Receiver Reference* for a citation.

## 7.1 Summary of the Procedure

**Position data.** GIS data acquisition uses differential GPS to determine the positions of objects. DGPS corrections may be transmitted from the base station to the rover by radio to yield position fixes in real time, or they may be postprocessed to compute position fixes before data analysis. RTK may also be used to determine positions, although it offers more limited support for collecting feature data.

**Feature data.** Feature data (descriptions of geographic features) generally is entered manually at the rover, and its structure depends entirely on the needs of your application. This data customarily is entered through an Asset Surveyor attached to the rover.

The Asset Surveyor is a handheld device with a full alphanumeric keypad and expanded LCD display. It can be configured to prompt you for the specific data items your application requires, and to accept one-keystroke entries in yes/no and multiple-choice fields. Its bar code reader can be used to read in selections from a pre-printed sheet of more extensive attribute descriptions. These features make an Asset Surveyor a much more efficient and reliable data entry tool than a receiver alone.

RTK requires you to use a Survey Controller instead of an Asset Surveyor. The Survey Controller uses the same hardware as the Asset Surveyor, but its firmware is different; it lets you identify features by feature codes (such as 'FH' for a fire hydrant), but it does not have the Asset Surveyor's extensive data entry functions.



## 7.2 Equipment and Software Require

GIS rovers and base stations are sold as complete kits (systems) which contain all of the equipment and supplies you need. You can also assemble your own systems by adding items to your existing equipment.

For the base station, you need:

- A Series 4000 receiver. The recommended receiver is the GIS Surveyor. Other appropriate receivers are listed in Table 1-4.
- A GPS antenna and antenna cable. The Compact L1 Antenna is recommended.
- A tripod to support the GPS antenna.

For a permanent base station, the antenna may be pole-mounted in an unobstructed place on the roof of a building.

- A suitable power source. Where line power is available, use an OSM2, backed up by an uninterruptible power supply if necessary. In other situations, use long-lasting batteries such as Trimble's 10 AH battery packs, which last about 15 hours per charge.
- If rovers must compute position fixes in real time, a digital radio transmitter or transceiver, a modem, and an antenna.

The modem may be integrated with the radio, or may be a separate unit.

Trimble's TRIMTALK 900 transceiver, while intended primarily for RTK, may be used for DGPS operations at line-of-sight distances in the United States and certain other nations.

Trimble also sells a radio modem for use with the TRIMTALK 900. Trimble can recommend other radio equipment for particular types of DGPS operations.

- Cables for connecting the radio antenna to the radio, the radio to the modem (if they are separate units), and the modem to the receiver's serial port.

- A tripod or other suitable support for the radio antenna. The GPS antenna's tripod is *not* suitable, since the two antennas should be separated by at least a meter or so.
- If data will be logged directly to a computer, the computer, a download cable, and a copy of URS for DOS.

For each rover, you need:

- A Series 4000 receiver. If the rover will be used to compute position fixes in real time, it must have the RTCM-104 Input Option.

Note that the RTCM-104 Input Option is a prerequisite for the Output Option, so any receiver equipped for use as a base station may also be used as a rover.

The GIS Surveyor is the recommended receiver. Other appropriate receivers are listed in Table 1 -4.

- A GPS antenna and antenna cable. The Compact Dome Antenna is recommended.
- A suitable power source. Trimble recommends long-lasting batteries such as Trimble's 1 0AH battery packs.
- An Asset Surveyor (optional, but strongly recommended; required for recording feature codes and attributes).
- If the rover must compute position fixes in real time, a digital communications receiver or transceiver, a modem, and an antenna.

The modem may be integrated with the radio, or may be a separate unit.

Trimble's TRIMTALK 900 transceiver may be used; see the discussion in the list of base station equipment, above.

- Cables for connecting the radio antenna to the radio, the radio to the modem (if they are separate units), and the modem to the receiver's serial port.

- A rigid-frame backpack to carry the receiver and support the radio antenna, and a rangepole to support the GPS antenna.

You will need the computer program PFINDER for project planning and definition, downloading data dictionaries to an Asset Surveyor, postprocessing DGPS data, and exporting data to a GIS.



# A Common Operations

---

## A.1 Connectors and Cables

This section contains only information that is likely to be useful in the field. For complete descriptions of the connectors and cables, including pin-outs and electrical specifications, see Appendix A of the *Receiver Reference*.

### A.1.1 How to Supply Power to a Portable Receiver

Portable receivers can input power through the PWR -- I/O1 and PWR 2&3 (or POWER) connectors.

**OSM2.** If line power is available, the receiver may be run from an OSM2.

The OSM2's LEDs indicate its status:

- PWR (orange): AC voltage is applied.
- FAST CHARGE (orange): batteries are being bulk charged.
- FLOAT CHARGE (green): batteries are at least 90% charged and are being trickle-charged.

**Table A-1. Connectors on the Rear Panel Connectors**

Portable Receivers	Rack-Mounted Receivers	Function
—	AC INPUT	AC power input: 100/120/220/240 volts at 47-- 63Hz. Receiver must be configured for the available voltage; see the <i>Receiver Reference</i> for details.
PWR--I/O 1	—	Serial port 1. Power port 1; 10.75- 35VDC input or 12 VDC output.
I/O 2	—	Serial port 2 (if Two or Four Serial Port Option is installed). Power output with direct connection to power lines on PWR-- I/O1.
PWR 2&3 or POWER	—	Serial port 3 (if Four Serial Port Option is installed). Power ports 2 & 3; 10.75-- 35VDC input or 12 VDC output on each port.
AUX	—	Serial port 4 (if Four Serial Port Option is installed). Event input (if Event Marker Input Option is installed). 1 pulse/second output (if option is installed).
—	12 VDC IN	11 to 35VDC power input.
—	DATA I/O PORT 1	Serial port 1.
—	DATA I/O PORT 2	Serial port 2 (if Two or Four Serial Port Option is installed).
—	DATA I/O PORT 3 DATA I/O PORT 4	Serial ports 3 & 4 (if Four Serial Port Option is installed).

**Table A-1. Connectors on the Rear Panel Connectors (Continued)**

—	EVENT MARKER	Event mark input (if Event Marker Input Option installed).
—	1 PPS OUT	1 pulse/second output (if option is installed).
ANTENNA	GPS ANTENNA	Antenna input.
EXT REF	EXT REF	External Frequency Input (if option is installed).

The OSM2's four battery slots may be used to recharge camcorder batteries, whether the receiver is operating or not. Plug the external battery's standard cable into the OSM2's 5-pin LEMO connector instead of the receiver's connector. Batteries take about 8 hours to bulk-charge to 90% of capacity, and another 8 hours to trickle-charge to 100% capacity. Batteries may safely be left on charge indefinitely.

If you plug a battery into the OSM2 and the green light immediately appears, check the battery for a blown fuse.

**Batteries.** When a receiver is run on batteries, the batteries may have to be changed during operation. To change batteries, simply plug a fresh battery into the unoccupied power connector, then disconnect the used battery.

If you are using camcorder batteries with a dual or quadruple battery input cable, you can simply attach a new battery to an unused cable clip, then unclip the used battery.

To get the most use possible out of an old battery, attach the new battery and then check the main *Status* screen periodically. The last line of the screen will show you which power port the receiver is using. For example this screen shows that it is using power port 2:

```

0492-137-0 LOGGING FOR 0:01 |ELEV/AZM
APPROX. MEMORY LEFT: 94 HR |POSITION
SU02,19,06,18 | DATE
PWR2+[_____] * 2:05:03 PST/24 | MORE

```

The receiver continues using the old battery until its useful charge is exhausted, then switches to the new battery. When the main *Status* screen shows that the receiver has switched batteries, remove the old battery.

This technique works with camcorder batteries even if you are using only one battery input cable. The dual battery input cable attaches one battery terminal to PWR2 and the other to PWR3. The quad cable attaches one pair of terminals to each port.

**Battery Module.** This device holds two camcorder batteries, and attaches to the bottom of a portable receiver. It is used primarily with the 4000SE, 4000SSE, and 4000SSi, but is compatible with other receivers as well.

To install the Battery Module, simply slide its plastic tabs into their receptacles on the receiver and rotate the knurled knobs until snug. The battery module automatically mates to the receiver's PWR 2&3 connector when attached. One battery feeds the POWER 2 port, and the other feeds POWER 3. Thus the receiver runs off one until it is exhausted, then automatically switches to the other.

To replace an exhausted battery, push the release button on the battery case and tap the battery lightly. The exhausted battery should spring out. To insert the new battery, slide it in until it clicks home. Be sure that the + sign on the battery is oriented up as indicated on the case. The battery will not slide in completely if not properly oriented.

Note that on receivers with the Four Serial Port Option only one battery can be used, because serial I/O port 3 replaces the POWER 3 port on the connector.

**Changing fuses.** All Trimble power sources except the Battery Module have user-serviceable dual fuses. On battery-operated power supplies, use 5-ampere ATO automobile fuses as replacements. For AC power supplies, see the specifications printed on the back panel of the device itself.



When a fuse blows:

1. Find and correct the cause of the incident.
2. Inspect *both* fuses, and replace either or both, as required.

The only “normal” cause of blown fuses is a short circuit caused by an object other than a receiver; for example, by accidental contact between the end of the cable and a conductor. If this is not the cause, you must assume that the battery, cable, or receiver is malfunctioning. You can identify the failing component by substitution (at the possible cost of more blown fuses). The failing component must be repaired before it can be used again.

In the OSM2 and in hard battery packs, the fuses are in a small compartment in the case. Snap the compartment open to replace the fuses. In soft battery packs, the fuses are in-line in the power cable, near the battery terminals. Open the battery pack to reach them. All power cables sold as separate products have dual in-line fuses.

### **A.1.2 How to Draw Power from a Portable Receiver**

A portable receiver can supply 12VDC at 0.5ampere through ports I/O 2 (with the Two or Four Serial Port Option) or PWR -- I/O1. This power output can be used to operate a low-power remote device such as a remote display or a radio modem. The remote device must use a soft-start sequence so that the initial current drain is not too large. This technique may also be used to recharge batteries, but only if the receiver is powered from a non-battery source such as an OSM2.

To enable power output:

1. Connect PWR 2&3 (or POWER) to a power source.
2. Disconnect PWR -- I/O1 from any power source.
3. Connect the remote device to I/O 2 or to PWR -- I/O1.
4. From the *Control* menu, select POWER CONTROL. Press the CHANGE softkey to enable the power output.

5. Turn on the remote device.

Rack-mounted receivers can display the POWER CONTROL screen, but do not provide power output.

## A.2 Connecting a Serial Port to Another Device

All Series 4000 receivers have one or more serial ports which can be used to exchange data with other devices such as computers, radio modems, and navigation instruments. The connectors that attach to each port are shown in Table A-1. With an appropriate cable (see below), you use the same basic procedure to connect any receiver port to any type of device.

**Portable receivers.** All available ports are presented through the connectors on the back panel, as shown in Table A-1. The following sections identify cables that you can use to attach these connectors to standard serial devices.

The OSM2 provides serial output through a standard DE9S connector. The connector presents serial port 1 if the OSM2 is plugged into PWR I/O 1; it presents serial port 3 if the Four Serial Port Option is installed and the OSM2 is plugged into PWR 2&3 (or POWER).

**Rack-mounted receivers.** Rack-mounted receivers present the serial ports on four dedicated connectors, DATA I/O PORT 1 through DATA I/O PORT 4. All four connectors are present on the rear panel whether or not they are active. All four connectors are DE9S's in a standard DCE configuration.

### A.2.1 Choice of Data Cable

To connect a receiver to the 9-pin serial port connector on an IBM PC or PC-compatible system, use the appropriate cable directly.

To connect a receiver to a 25-pin serial port connector on an older IBM PC or PC-compatible system, attach a 25- to 9-pin adapter to the end of the cable.

To connect a receiver to a DCE device (such as most modems), attach a null modem cable (Trimble part number 17202) to the end of the cable.

Trimble recommends using the following standard cables:

- For a portable receiver, Trimble part number 18826 connected to PWR I/O 1 (port 1) or PWR 2&3 (port 3), or Trimble part number 18827 connected to I/O 2 (port 2) or AUX (port 4).
- For a portable receiver attached to an Office Support Module 2 (OSM2) through the OSM2's data connector, Trimble part number 14284 connected to the OSM2's serial port.
- For a rack-mounted receiver, Trimble part number 14284 connected to any available DATA I/O PORT.



---

**Note** – When communicating with a device via the 4000A/S compatible remote protocol, *do not* attach the device to a serial port until you have configured the port's baud rate and data format. The receiver may misinterpret data input through an unconfigured port as a command, which could corrupt the internal database.

If you do make this error and the receiver locks up or behaves oddly, turn the receiver off and back on. If that does not help, reset the receiver's parameters to their factory default values. If the problem still does not go away, call Trimble Service.

---

## A.2.2 How To Configure a Serial Port

To use one of the receiver's serial ports to transfer data between the receiver and a computer or other device, you must configure that port's parameters to match those of the corresponding port on the other device.

In general, there are no “correct” values for serial interface parameters. It is only necessary that the two communicating devices be set to the same values.

To use a serial port to do external data logging or to download data, Trimble suggests a baud rate of 38,400 (or slower if the computer's serial ports cannot be set that high), a data format of 8 data bits, odd parity, 1 stop bit, and a FLOW CONTROL setting of XON/XOFF .

**How to set the parameters.** Press the [CONTROL] key. From the *Control* menu, press the MORE softkey until you see the BAUD RATE/FORMAT softkey; then press that key.

The receiver displays this screen:

```
SERIAL PORT 1 SETTINGS                               MORE
  BAUD RATE [   9600   ] <-- CHANGE
    FORMAT [ 8-ODD--1 ] <-- CHANGE
  FLOW CONTROL [ XON/XOFF ] <-- CHANGE
```

Press the MORE softkey until the first line displays the desired port number

Press each CHANGE softkey until the desired parameter value appears. Then press the [CLEAR] key twice to return to the status display.

**Table A-2. Serial Port Parameters**

	Port 1	Port 2	Port 3	Port 4
<b>Baud Rate</b>	110, 300, 600, 1200, 2400, 4800, 9600, 19,200, 38,400, 57,600	50, 110, 300, 600, 1200, 2400, 4800, 9600, 19,200, 38,400, 57,600	Same as por t2	Same as port 2
<b>Data Format (data bits, parity, stop bits)</b>	8,None,1 8,Even,1 8,Odd,1 8,None,2 7,Even,1 7,Odd,1	Any combination of 7 or 8 data bits; even, odd, or no parity; 1 or 2 stop bits	Same as port 2	Same as port 2
<b>Flow Control</b>	XON/XOFF or NONE	XON/XOFF, CTS/RTS, or NONE	Same as port 1	Same as port 2

### A.2.3 How to Use a Remote Protocol

A *remote protocol* is a protocol (a system of rules) that remote devices may use to control a receiver, or request information from it, through a serial port.

Series 4000 receivers support two remote protocols:

- **DATA COLLECTOR COMPATIBLE:** Used by Trimble data collectors and similar handheld data loggers, and for updating receiver firmware from a computer. For information about this protocol, see the *4000SE/SSE RS-232 Interface Data Collector Format Specifications Manual*.
- **4000 A/S COMPATIBLE:** Used by certain older Trimble application programs. See the *Model 4000 Remote Control Interface Manual*.

**To select a remote protocol.** From the *Control* menu, select REMOTE PROTOCOL. The receiver displays this screen:

```
REMOTE INTERFACE PROTOCOL
[ DATA COLLECTOR COMPATIBLE ] <-- CHANGE
(STX,DATA,CHECKSUM,ETX)
```

Press the CHANGE softkey to toggle the remote protocol selected.

For information about what value to set, consult the other device's documentation.

### A.3 Setting the Power-Up Parameters to Their Defaults

It is often useful to return a receiver to a known state, either because you know certain parameters have been changed, or because your receiver is not behaving correctly and you want to eliminate changed parameter settings as a possible cause.

There are two ways to reset a receiver to a known state: by using the DEFAULT CONTROLS screen to reset the receiver immediately, and by using the POWER-UP CONTROL screen to make it reset itself automatically each time it is turned on. Both techniques reset a group of parameters called the *power-up parameters*. These include most of the parameters that can affect a receiver's performance.

**To reset the receiver immediately.** From the *Control* menu, select DEFAULT CONTROLS. The receiver displays this screen:

```
INITIALIZE ALL CONTROLS TO DEFAULT |
SETTINGS AND RESTART RECEIVER      |
                                     | NO
ARE YOU SURE ?                     | YES
```

Press the YES softkey. The receiver resets the power-up parameters and restarts itself (as if it had been turned off and back on).

**To make the receiver reset controls when turned on.** From the *Control* menu, select POWER-UP CONTROL. The receiver displays this screen:

```
POWER-UP INITIALIZATION CONTROL
[ DO NOT DEFAULT CONTROLS ] <-- CHANGE
      AT POWER UP
```

Press the CHANGE softkey to make the third line say 'DEFAULT CONTROLS'.

**List of power-up controls.** The power-up controls are:

- CYCLE PRINTOUT parameters
- MASKS/SYNC TIME parameters (not Quick Start, FastStatic or Kinematic parameters)
- NMEA-183 OUTPUT parameters
- 1 PPS OUTPUT
- POSITIONING MODES (excluding weighted solution mode)
- POWER CONTROL
- REMOTE PROTOCOL
- RTCM-104 INPUT parameters
- IGNORE SV HEALTH (for positioning)
- L1 TRACKING (receivers with L1/L2 P-Code Option only)

Note that the following parameters are *always* reset at power-up, regardless of how POWER-UP CONTROL is set:

- RTK OUTPUT CONTROL (except after power-fail)
- RTK ROVER CONTROL (except after power-fail)
- BACKLIGHT TIMEOUT
- L2 Tracking (receivers with L1/L2 P-Code Option only)

## A.4 Configuring Single or Dual-Frequency Operation

Receivers that have the L1/L2 P-Code Option and the Dual Frequency Option may be configured for single-frequency operation (L1 only) or dual-frequency operation (L1 and L2). This includes all dual-frequency receivers except the 4000SE Land Survey receiver.

Either configuration is acceptable for single-frequency procedures. Single-frequency operation logs a smaller volume of data, and so is preferred if you are concerned about running out of memory in the receiver.

A receiver must be configured for dual-frequency operation when it is used for dual-frequency procedures. The dual-frequency procedures are dual-frequency static surveying and Real-Time Kinematic (RTK) with automatic initialization.

**Configuring the receiver.** You configure the receiver for single or dual-frequency operation with the *Control* menu's L1/L2 TRACKING screen.

1. From the *Control* menu, select L1/L2 OPERATION. The receiver displays a screen like this:

```
L1/L2 TRACKING: P,C/A-CODE | L1 TRACKING
                  P,Y-CODE  | L2 TRACKING
                  |
                  |
```



**Note** – The above display refers to the 4000SSi. For the 4000SSE, the label P,Y-code is substituted by P,X-code. These refer to equivalent L2 tracking modes between receiver types.

For single-frequency operation, line 1 should say C/A-CODE and line 2 should say DISABLED.



For dual-frequency operation, line 1 and line 2 should both appear as above.

2. Press the L1 TRACKING and L2 TRACKING softkeys, if necessary, until line 1 and line 2 display the proper values.

## A.5 Entering Supplementary Data

“Supplementary data” is data *other* than satellite data or computed data that may be recorded in a data file. It includes:

- *Event marks*: serial-numbered, time-stamped records in a data file.
- *Event mark comments*: Alphanumeric messages associated with event marks.
- *Field notes*: Alphanumeric messages associated with a survey or data logging session as a whole.
- *Surface meteorological data*: Data that describes surface meteorological conditions at the time and place data is logged.

All types of supplementary data may be entered only while data is being logged.

To get ready to enter any type of supplementary data:

1. **While starting a static survey or data logging session.** After you enter the antenna information, the receiver displays this screen:

```
STATION/SESSION: 2345-093-1|START SURVEY
APPROX. MEMORY LEFT: 8.4 HR| USER INPUT
| CHANGES
PWR1+[*****] 2:01:59 PM PST|
```

2. **While performing a static survey or data logging session.**  
Press [F10] (DATA), if necessary, to display the SURVEY screen.

```

SURVEY:                                | USER INPUT
                                         |   CHANGES
                                         |
                                         | END SURVEY

```

3. **While performing a FastStatic or kinematic survey.** Return to the surveying procedure's main information screen, if necessary. The screen will resemble this one (an example from the FastStatic surveying procedure):

```

FAST STATIC: COLLECTING DATA |
                               |      ABORT
MARK ID: ___0001    5 SVS | INPUT/CHNGS
TIME REMAINING: 14:59    | END SURVEY

```

Press the INPUT/CHNGS softkey. The receiver will display a screen similar to this one:

```

FAST STATIC:                                |
                                             | USER INPUT
                                             |   CHANGES
                                             |   STATUS

```

4. Press the USER INPUT softkey. The receiver will display a screen similar to this one (an example from the static surveying procedure):

```
SURVEY INPUTS:      |      MARK EVENT NOW!  
                    |      EVENT MARK COMMENTS  
                    |      FIELD NOTES  
                    |      SURFACE MET DATA
```

Proceed to the directions for entering the type of supplementary data of interest to you.

### A.5.1 How to Enter Event Marks and Comments (Only with Event Marker Input Option)

An event mark records the precise time when a particular events occurred. It can be generated by an electrical signal, as from the closing of a photogrammetric camera's shutter, or by input through the receiver's keypad. Keypad input is usually reserved for unusual events, such as an accident that may have affected a receiver's satellite tracking during a survey.

Event mark comments are alphanumeric notes associated with particular event marks. to record information in the course of a survey. For example, if you enter an event to record an instance of interference with a receiver's satellite tracking, you can enter a comment that describes the cause of the interference.

#### To create an event mark and enter a comment:

1. Display the INPUTS menu as explained in “Entering Supplementary Data,” above.
2. Press the MARK EVENT NOW! softkey. This creates an event mark, time stamped with the precise GPS time at which you pressed the key. The receiver displays a screen that says NEW

EVENT MARK ENTERED and shows the event mark's ID. Press the [CLEAR] key to return to the USER INPUT menu.

3. Press the EVENT MARK COMMENTS softkey. The receiver displays this screen:

```
COMMENTS FOR EVENT: 0003      |NEXT ID
                                |PREV ID
                                |
                                |
```

The first line shows the ID of the last event mark created. You can select a different event mark by pressing the NEXT ID and PREV ID softkeys.

4. When the first line shows the ID of the event mark for which you want to enter a comment, press [ENTER]. The receiver displays this screen:

```
COMMENTS FOR EVENT:           |ALPHA
                                |
                                |
                                |ACCEPT
```

5. Enter a comment up to three lines long. If the ALPHA softkey is available, you must press it to enter alphanumeric mode if you want to enter an alphanumeric comment.
6. When the comment is complete, press ACCEPT or [ENTER]. The receiver returns to the INPUTS menu.

**To enter a comment for an existing event mark.** Follow the procedure above, but skip step 2 (pressing MARK EVENT NOW!). Select the appropriate event mark in step 3.

You can enter any number of comments for a single event mark.

Note that you cannot edit or delete a comment once you have accepted it.

### A.5.2 How to Enter Field Notes

Field notes are notes that are associated with a survey or other data logging session as a whole. They are time-stamped, however, enabling postprocessing software to associate each one with the part of the survey during which you entered it. They are useful for entering information such as descriptions of survey marks.

To enter a field note:

1. Display the INPUTS menu as explained in “Entering Supplementary Data,” above.
2. Press the FIELD NOTES softkey. The receiver displays this screen:

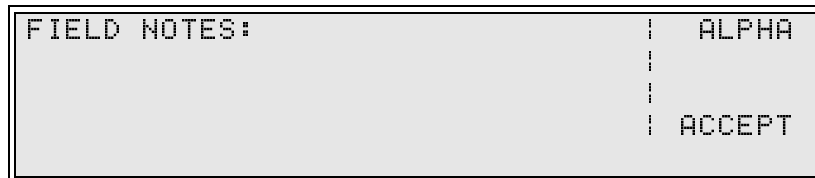

3. Enter a field note up to three lines long. If the ALPHA softkey is available, you must press it to enter alphanumeric mode if you want to enter an alphanumeric note.
4. When the field note is complete, press ACCEPT or [ENTER]. The receiver returns to the INPUTS menu.

You can enter any number of field notes for a session. Note that you cannot edit or delete a field note once you have accepted it.

### A.5.3 How to Enter Surface Meteorological Data

Surface meteorological data describes surface meteorological conditions at the time and place where a survey or other data logging session takes place.

**To enter surface meteorological data:**

1. Display the INPUTS menu as explained in “Entering Supplementary Data,” above.
2. Press the SURFACE MET DATA softkey. The receiver displays this screen:

```
SURFACE MET DATA: |
TEMP: (DRY)+020.0 (WET)+000.0 ̈C | UNITS
PRES: 1013 millibars |
RH: 50 % WEATHER CODE: 99999 |
```

The lines on the screen show:

Line 2 - Dry and wet temperatures.

Line 3 - Atmospheric pressure.

Line 4 - Relative humidity and NGS standard weather code.

3. Enter appropriate values in the fields.

The UNITS softkey toggles the display between metric units (temperatures in Celsius, pressure in millibars) and English units (temperatures in Fahrenheit, pressure in inches of mercury).

You can change the sign of the wet or dry temperature by placing the cursor at the sign and pressing the [YZ--9] key (for “minus”) or the [+0] key (for “plus”). Note that this is different from most other signed fields, which expect you to press a PLUS/MINUS softkey.

4. To leave the screen, press [ENTER] until the cursor is at the last field, then press it once more. The receiver returns to the INPUTS menu.

## A.6 Adjusting Local Time Zone and Time Displays

You can adjust the displayed time, set the time zone identifier to suit your locality, and select the format of date and time displays.

### A.6.1 Local Time Zone and Time Offset

The receiver's local time is equal to UTC plus or minus a local time offset that you can change in 15-minute increments. You cannot “set the time” as you would on a clock, since the receiver synchronizes itself to GPS time whenever it is tracking one or more satellites.

Press the [CONTROL] key. From the *Control* menu, press the MORE softkey until you see the ADJUST TIME ZONE softkey; then press that key.

The receiver displays this screen:

```
ADJUST LOCAL TIME:          | FORWARD
 (APPROXIMATE)  FRI 10:50 AM | BACKWARD
TIME OFFSET(LOC-UTC): -7:00 |
TIME ZONE IDENTIFIER= LOC   |
```

Press the FORWARD or BACKWARD softkey until the correct local time appears on the second line.

Use the keypad to change the time zone identifier. It is always entered in alphanumeric mode.

Press [ENTER] to accept any changes you have made and leave the screen. Then press [CLEAR] to return to the *Status* display.

### A.6.2 Time Display Format

To select the time display format, press the [STATUS] key, then the DATE softkey. The receiver displays this screen:

```
FRI 04-JUN-93 17:51:13 UTC | UNITS
JULIAN DAY: 155 |
GPS WEEK: 699 |
TIME OFFSET(LOC-UTC): -7:00 |
```

Press the UNITS softkey to select the time display format. Possible formats are:

- Twelve hour local time; *e.g.*, '2:33:0 9PM PST'.
- Twenty-four hour local time; *e.g.*, '14:33:09PS T/24'.
- Twenty-four hour UTC; *e.g.*, '21:33: 09UTC'.

Press [Cl EAR] to return to the *Status* display.

### A.7 Using Local Datums and Projections

Series 4000 receivers customarily produce position fixes in the WGS-84 datum. This datum is the current international standard for global mapping and positioning applications.

Local mapping applications customarily use *local datums* which are defined to correspond more closely to the surface of the earth in the region of interest. They may also use projections of a local datum onto a plane. Such a projection is called a *local zone*. In a local zone, positions are customarily described by a *northing* and an *easting*: the distance north and east from a specified origin to the position of interest.



Receivers also can display positions in a local datum and local zone of your choice, as described in the section *Displaying Your Position* in Chapter 6. The *Local Datum/Zone Pos* cycle printout makes these positions available outside the receiver, as described in the *Receiver Reference*.

Displaying data in a local datum or zone does not affect other receiver functions, which continue to use the WGS-84 datum. For example, logged position fixes and positions in other cycle printouts are always expressed in the WGS-84 datum.

### A.7.1 How to Select a Local Datum or Local Zone

You can select one local datum and one local zone (one projection of a local datum) at a time. The selected local zone is customarily, but not necessarily, a projection of the selected local datum.

You select a local datum and local zone by running the program DATM4000 on a personal computer that is connected to one of your receiver's serial ports. This program is described in *Local Datum and Zones Option: Software Release Notes*.

You can make your receiver display position fixes in the selected local datum or local zone by choosing UNITS OF MEASURE from the *Modify* menu. The receiver displays a screen similar to this:

```
UNITS: LAT-LON = deg-min-sec  <-- CHANGE
        ANTENNA HGT = meters   <-- CHANGE
           TIME = 12 hr local  <-- CHANGE
           POSITION = WGS84 LLH  <-- CHANGE
```

Press the POSITION... CHANGE softkey to select the desired type of position display:

- WGS84 LLH: Latitude, longitude, and height in the WGS-84 datum (the receiver's standard datum).
- Local LLH: Latitude, longitude, and height in the local datum.

- Local NEH: Northing and easting in the local zone. (The displayed height is the local datum height.)

## A.8 Using and Caring for an Antenna

The following sections discuss the types of Trimble GPS antennas and antenna accessories that are commonly used with Series 4000 receivers.

Many of the antennas described here have *groundplanes*: large metal plates that surround an antenna's base. Figure A-1 shows a typical antenna with groundplane.

A groundplane reduces the multipath effects caused by the reflection of satellite signals off the ground, yielding cleaner data. It also provides reference points that are used in the procedures for measuring antenna height. Antennas with groundplanes are intended mainly for high-precision control surveys.

### A.8.1 Tripod with Tribrach

A tripod with tribrach and optical plummet is the standard type of support for antennas used in control surveys, and for all types of antennas at temporary base stations. Trimble sells a tripod and a tribrach with optical plummet, but any equipment intended for surveying applications may be used.

**Setup.** This procedure ensures that the antenna is positioned directly over the survey mark, and that its height is measured accurately

1. Set up the tripod over the survey mark.

The top of the tripod should be roughly at eye level. This makes it easier to adjust, and also reduces the risk of signal interference from near-by objects.

The antenna, when mounted, must have a clear line of sight to the satellites it will track during the survey. For suggestions on dealing with marginal visibility, see the section Entering Antenna Parameters.

2. Screw the tribrach base onto the tripod.
3. Use the optical plummet as a guide to center the tribrach over the survey mark. Level the tribrach. Check the optical plummet to be sure the tribrach is still centered; if it is not, recenter it and relevel it. Continue to check and adjust until the tribrach is both centered and leveled.
4. If you are using a procedure that requires a quick-release adapter, screw the quick-release adapter onto the antenna, and the quick-release bayonet on the tribrach adapter. Seat the adapter on the tribrach base and clamp it in place. Snap the quick-release adapter into the bayonet.

The section Quick-Release Adapter and Bayonet describes the quick-release adapter and bayonet in more detail.

5. If you are using a procedure that does not require a quick-release adapter, screw the antenna directly into the tribrach adapter. Seat the adapter on the base and clamp it in place.
6. Connect a receiver to the antenna and to a battery pack or other power source.

**Measuring antenna height directly.** This procedure measures the uncorrected height of an antenna.

An *uncorrected* height is a height measured by a specified procedure, such as the one described below. The uncorrected height must be converted to a corrected (true) height through a formula matching the procedure and the equipment being used. Trimble postprocessing software can perform this conversion automatically.

This procedure is suitable for any antenna that has a groundplane, and for certain other antennas such as the Compact L1/L2 antenna. The discussions of individual antennas, later in this section, specify the correct procedure for each type of antenna.

By recording your antenna height measurements in full detail, you minimize the risk of error. Experience has shown that inadequate field notes are one of the most common sources of lost survey data.

1. If the antenna has a groundplane with a north arrow, rotate the antenna until the arrow points toward true north.
2. Draw an overhead view of the antenna, including the north arrow, in your field notes. Identify the survey measurement that this drawing represents and the type of height measurement you are taking (an uncorrected measurement). Note the type of antenna you are using.
3. Assemble a Trimble measuring rod. Move to the north side of the antenna and put the pointed end of the rod on the center of the survey mark. Slip the rod into a notch in the groundplane or antenna where you can measure without interference from the tripod legs, and read the antenna height at the inside bottom edge of the notch. Note the notch number and height measurement on your drawing.
4. Go a third of the way clockwise around the antenna. Measure the antenna height again and record the notch number and height. Go another third of the way around, and measure and record the notch number and antenna height a third time.
5. Your three raw measurements should agree within about 5 mm. If they do not, repeat all three measurements. If they still do not agree, recenter and relevel the antenna and try again.
6. Record the average of the three raw measurements. This is the antenna's *uncorrected* height.

It is good practice to measure the antenna height twice, by different methods, to catch measurement or calculation errors in the field. If

there is cause for concern that the tripod may have shifted during the observation, it is also prudent to re-measure the antenna height at the end of the observation. Two possible procedures are:

- Repeat the measuring rod procedure above, using the other unit of measure on the measuring rod. That is, if you took the first measurement in English units, use metric units; if you took the first measurement in metric units, use English. Convert one measurement to the units of the other. The two measurements should agree within 5 m m.
- Measure the corrected antenna height, using either of the two procedures described below. Remember that corrected measurements are usually less accurate than uncorrected measurements, and should not be expected to agree within 5 mm.

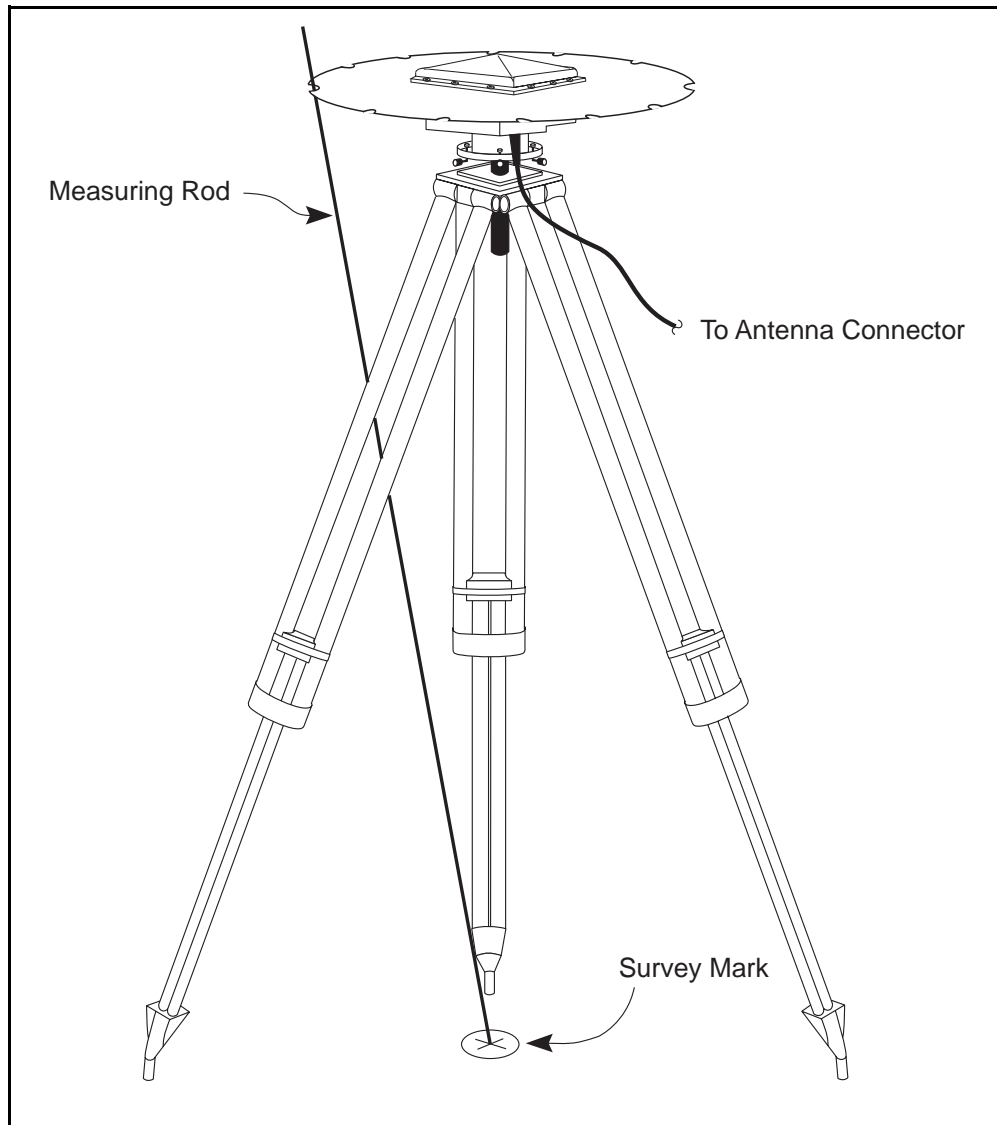

**Figure A-1. Measuring Uncorrected Antenna Height Directly**

**Measuring antenna height indirectly.** This procedure actually measures the diagonal distance from a reference point on the tripod head to the reference mark beneath the tripod. It can be used with any type of antenna, including some whose height cannot be measured directly, such as the Compact Dome Antenna. The procedure is more time-consuming and less accurate than the direct method described above, though. Therefore it is not recommended for high-precision surveys or for antennas with groundplanes, except as an independent check for a direct height measurement.

1. Center and level the tripod head within the tolerances of your survey and the surveying procedure you are using.
2. Locate a reference point on the tripod head or tribrach. The reference point should have a clear line of sight to the reference mark beneath the tripod. (See Figure A-2.)

Note that you can perform this step and the next one in the office, and need not repeat them for each height measurement.

3. Measure and record the horizontal distance from the reference point to the vertical axis of the antenna ( $C_h$  in Figure A-2) and the vertical distance from the reference point to the platform of the tripod head or tribrach ( $C_v$  in Figure A-2).
4. Draw a side view of the antenna and tripod in your field notes. Identify the observation that this drawing represents and the type of height measurement you are taking (an indirect, uncorrected measurement). Note the type of antenna you are using, and show the location of the reference point you have chosen.
5. Use a measuring rod to measure the diagonal distance from your reference point to the reference mark ( $H_u$  in Figure A-2). This is the antenna's *uncorrected* height. Record it in your field notes.

6. Use the Pythagorean theorem to compute the height of the plane of the reference point above the reference mark.

$$H_u^2 = H_v^2 + C_h^2$$

$$H_u = \sqrt{H_v^2 + C_h^2}$$

7. The antenna's corrected height is the sum of  $H_u$ ,  $C_v$ , the height of the quick-release adapter and bayonet if they are present, and the antenna's correction ( $C_a$ ), given in Table A-3:

$$H_C = H_u + C_v + 10.0 \text{ cm} + C_a \quad (\text{with quick-release})$$

$$H_C = H_u + C_v + C_a \quad (\text{without quick-release})$$



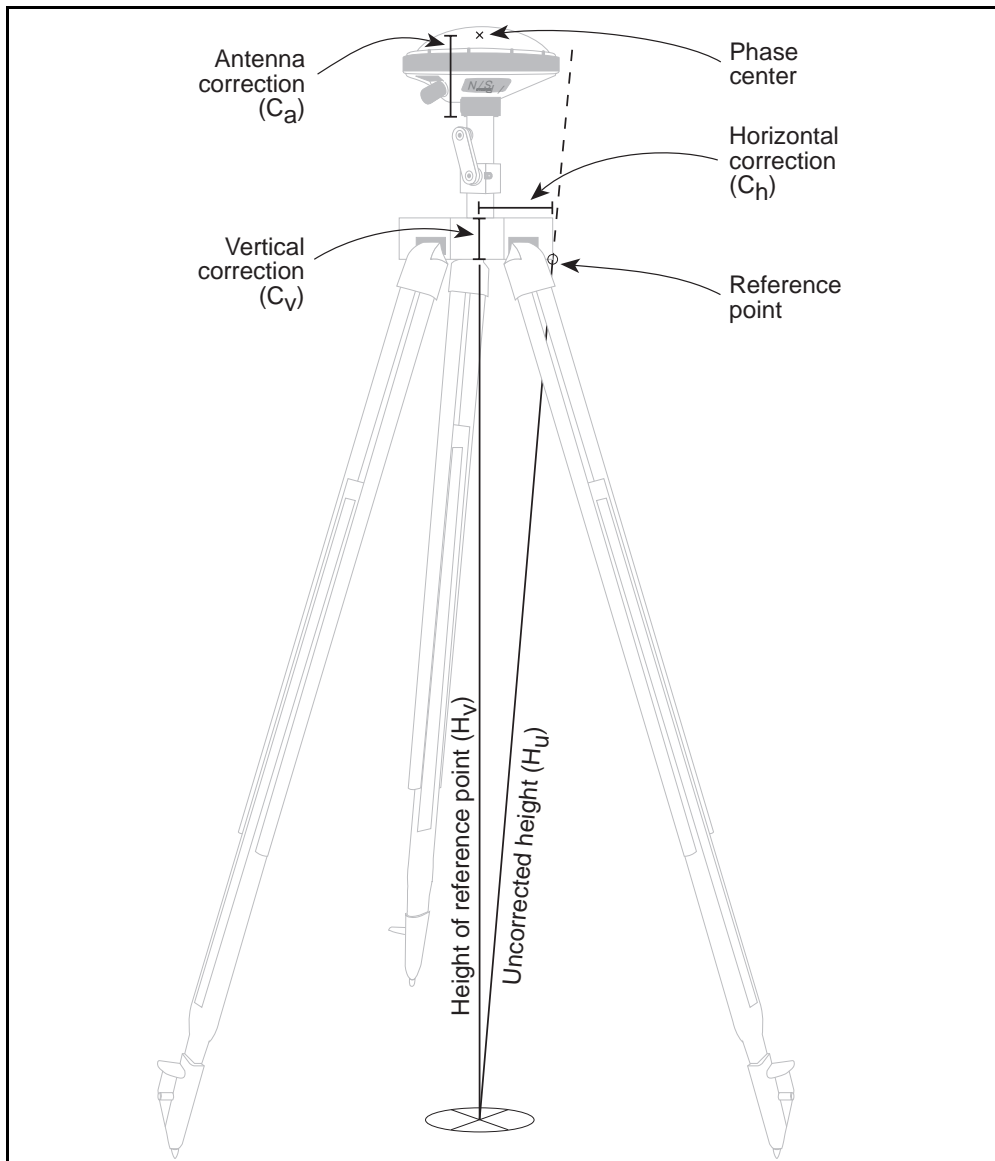

**Figure A-2. Measuring Antenna Height Indirectly**

**Phase center error.** Note that an antenna's phase center often is not coincident with its physical center. This is due to electrical effects of the antenna's casing and active elements. The error is on the order of  $\pm 3$  mm; for high-precision surveys, it can be significant. To cancel its effects, use the same type of antenna on all receivers and orient them all in the same direction. (The Compact L1/L2 Antenna with groundplane may safely be used with a L1/L2 Geodetic Antenna, though.)

**Care.** The optical plummet is designed to be rugged, but it is also a precision instrument. It should be realigned periodically by a shop equipped to test and repair surveying equipment.

### A.8.2 Fixed-Height Tripod

Fixed-height tripods are becoming popular because they simplify the height measurement process. Such a tripod has a fixed-height measuring rod fixed on the vertical axis. To set one up, you simply place the tip of the measuring rod on the mark and release the tripod's legs, which automatically extend to the ground. Then adjust the tripod until the measuring rod's built-in level shows that it is vertical, and lock the legs in place.

**Measuring antenna height.** The height of the antenna is the sum of the tripod's height (in most models, 2.0 meters) and the antenna's vertical correction as given by Table A-3. This is a *corrected* height.

### A.8.3 Rangepole

The Trimble rangepole is the recommended support for rover antennas in operations with moderate precision requirements and short to moderate observation times.

**Setup.**

1. If you are using a data collector (an Asset Surveyor, Seismic Controller, or Survey Controller), slip the data collector bracket over the upper shaft of the rangepole. (The shaft must be at least partly extended to allow this.)

The bracket has two parts: a slide that goes over the rangepole shaft and a plate that holds the data collector. If the slide and plate are not assembled, loosen the screws on the side of the slide, slip them into the slots in the edge of the plate, and retighten them.

2. If you are using the quick-release adapter and bayonet, screw the bayonet onto the rangepole and the adapter onto the antenna. Seat the adapter on the bayonet. This is the customary way to mount an antenna on a rangepole.
3. If you are using the rangepole alone, screw the antenna onto the rangepole. This setup is equally suitable for most types of surveys, although it is somewhat less convenient.

Connect the receiver to the antenna and to a battery pack or other power source.

4. Extend the rangepole fully. Note the mark that runs part way around the rangepole's upper shaft, just above the rim of the lower shaft. Let the upper shaft drop until the top edge of this mark is level with the rim of the lower shaft, then lock the rangepole. You can check the rangepole for partial collapse at any time by verifying that this mark is still visible.
5. If you are using a data collector, pull the data collector bracket down to a convenient height. Slip the data collector's mounting clips over the bracket's plate.

**Use.** To survey a mark, place the base of the rangepole on the mark and hold the rangepole steady, in a vertical position, for the duration of the observation. Use the rangepole's level to maintain it in a vertical position.

You may steady the antenna and free your hands for other work by extending the rangepole's optional tripod support. (Early versions of the rangepole have a bipod, which provides three-point support in conjunction with the tip of the rangepole itself.) When you must let go of the rangepole you should use the support with care, since a rangepole with support is less stable than a real tripod under the best of conditions.

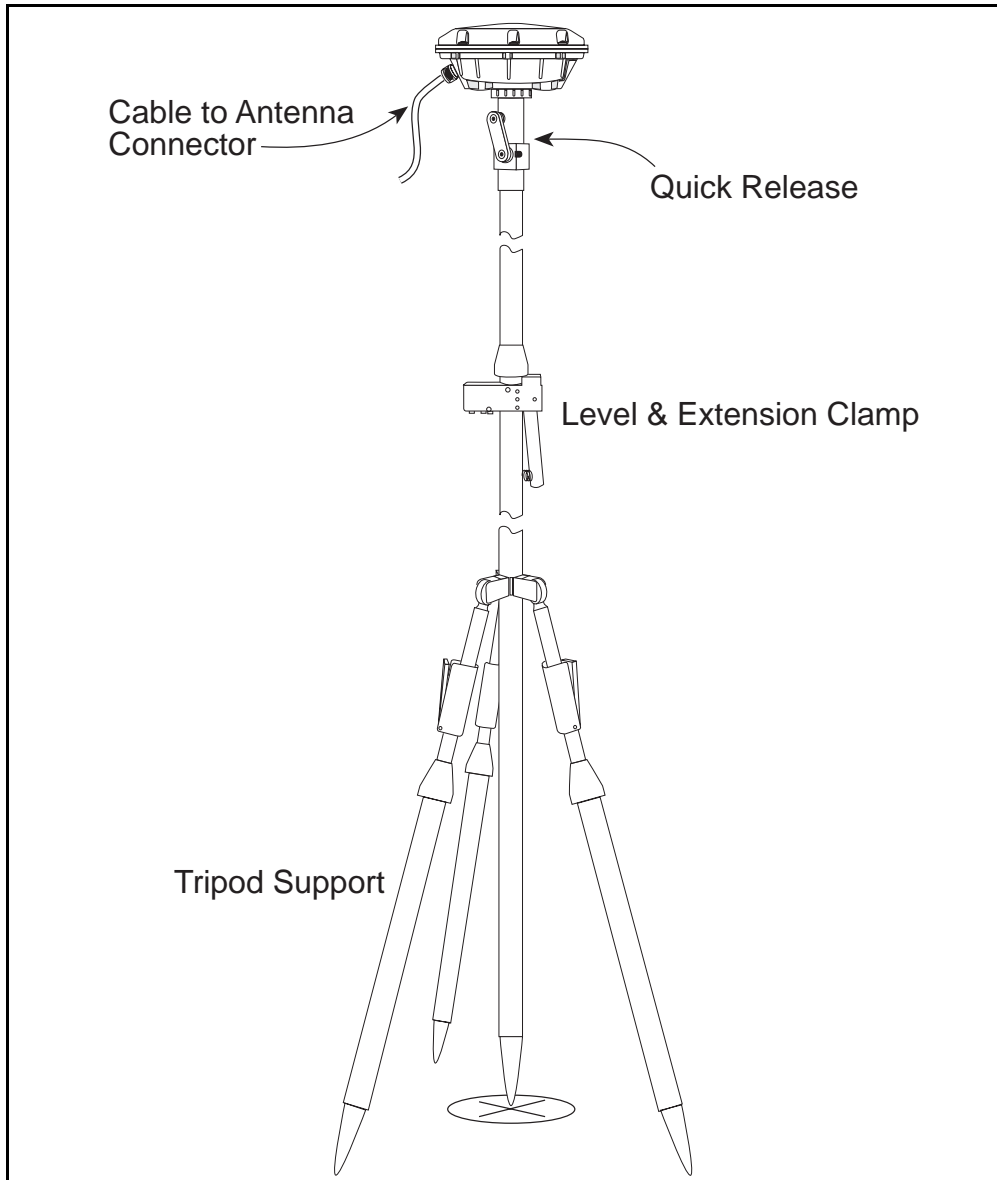

**Figure A-3. Rangepole with Support and Antenna**

**Measuring antenna height.** The current Trimble rangepole is 2.4 meters high. It replaces an earlier rangepole, which was 2.0 meters high. Thus the uncorrected height of any antenna mounted on a correctly extended rangepole is:

- Current rangepole: 2.500 m with quick-release adapter and bayonet; 2.400 m without.
- Original rangepole: 2.100 m with quick-release adapter and bayonet; 2.000 m without.

The antenna's corrected height is the sum of the uncorrected height and the antenna's correction factor, shown in Table A-3.

**Care.** The points at the bottom of the rangepole and the legs of the support may be replaced when they become worn or damaged. Although Trimble does not stock replacement rangepole points, they are standard items and should be available from any supplier of surveying equipment.

**Table A-3. Correction Factors for Antenna Height**

Type of antenna	Correction to height as measured from—			
	Base of housing ( $C_a$ , Figure A-2)		Bottom of groundplane	
Compact Dome	0.070 0m	2.76"	n/a	n/a
Compact L1/L2 with or without groundplane	0.062 5m	2.46"	0.006 9m	0.272"
Compact L1 with or without groundplane	0.062 5m	2.46"	0.006 9m	0.272"
Permanent Reference Station L1/L2	0.066 5m	2.62"	0.006 9m	0.272"
L1 Geodetic	0.066 0m	2.60"	0.006 3m	0.248"
L1/L2 Geodetic	0.069 2m	2.72"	0.009 5m	0.374"
L1/L2 Kinematic	0.069 2m	2.72"	n/a	n/a
4000ST and SST Kinematic	0.051 7m	2.04"	n/a	n/a

#### **A.8.4 Quick-Release Adapter and Bayonet**

The quick-release adapter and bayonet (Figure A-4) make it easy to attach and detach an antenna without disturbing its support. They are a convenient means of attaching an antenna to a range pole. They are also used with a tripod in procedures that require moving the antenna from one support to another, such as initialization by antenna swapping in a kinematic survey or an RTK survey.

In use, the quick-release bayonet is screwed onto a support and an antenna is screwed onto the adapter; then the adapter is snapped onto the bayonet. In storage, the bayonet often is screwed into the adapter to prevent them from accidentally separating. To set up an antenna, unscrew the bayonet from the adapter and reverse their positions.

Engage the adapter with the bayonet, press the release lever on the adapter and slip it over the bayonet. To disengage the adapter, press the release lever and lift.

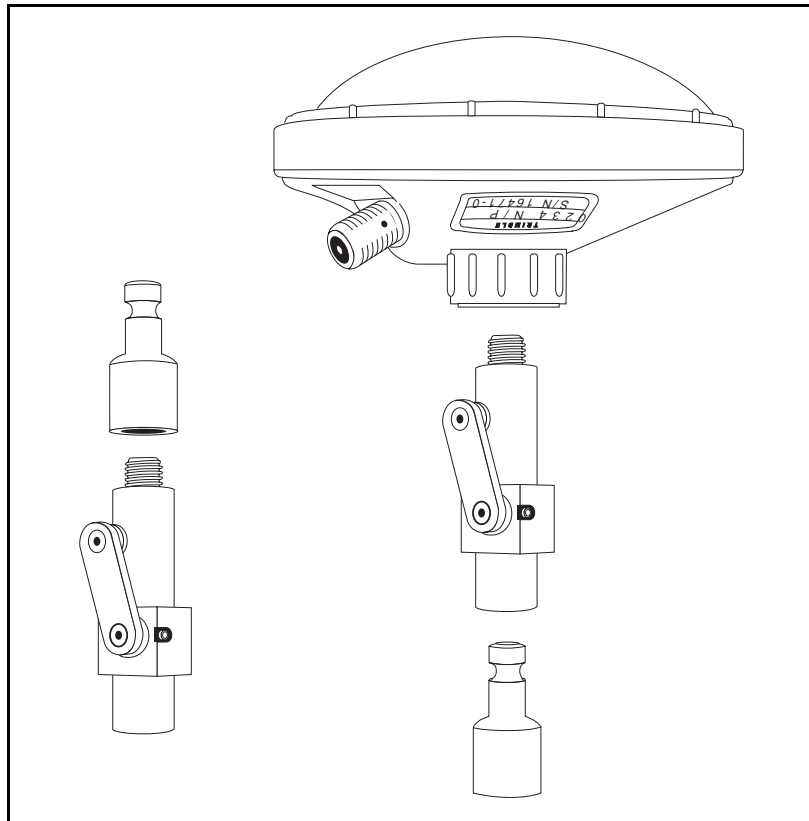

**Figure A-4. Quick-Release Adapter and Bayonet**

### **A.8.5 Magnetic Mount**

The magnetic mount (Figure A-5) is a disk-shaped device for temporarily attaching an antenna to a ferrous surface. It is most often used to attach a rover's antenna to the body of a car or truck.



The magnetic mount is intended for use in applications where accurate height measurements are not important, and it is convenient not to have to set up a tripod or rangepole for each observation. GIS data acquisition and RTK surveying are common examples. If you leave the antenna mounted on your vehicle for the duration of a survey, you can make observations without getting out.

**Setup.** Attach the magnetic mount to a part of your vehicle's body where it will have an unobstructed view of the sky. A flat, roughly horizontal place on the roof is usually best. Screw the antenna onto the magnetic mount's threads. You may use a quick-release adapter and bayonet if your application requires it.

Use the magnetic mount only with a light antenna. A heavy one could shake loose when you travel over rough terrain, causing damage to both the antenna and your vehicle. The Compact Dome Antenna is the lightest antenna that works with the Series 4000, and is the most appropriate one for use with the magnetic mount.

**Use.** Since the antenna tends to be “out of sight, out of mind,” you must be careful to stay aware of the antenna's visibility.

**Care.** When you handle and store the magnetic mount, keep it away from computer disks, credit cards, and other objects that may be damaged by its strong magnetic field.

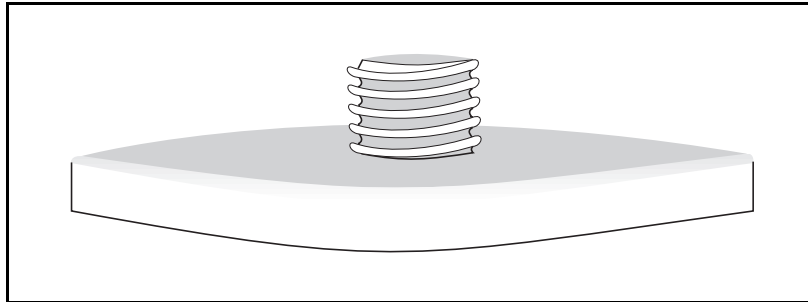

**Figure A-5. Magnetic Mount**

### A.8.6 Backpack Antenna Mount

The Backpack Antenna Mount is supplied with the light-weight backpack. It is a short rod with one threaded end which enables you to mount a GPS antenna on the backpack, so that you can transport and use the antenna without touching it.

The Backpack Antenna Mount is appropriate for autonomous operations and for medium-precision GIS data acquisition, where antenna height does not need to be measured or reproduced precisely.

The mount is also used to support a radio antenna in real-time operations such as RTK surveys.

**Setup.** Snap the Backpack Antenna Mount into the pair of clips on either side of the backpack frame. Screw an antenna onto the threads at the top of the mount. Or screw a quick-release bayonet onto the mount and use a quick-release adapter to mount the antenna.

### A.8.7 Antenna Cables

For antenna cable lengths of 35feet ( 10meters) or less, RG-58 cable may be used. For cable lengths over 35feet, RG-213 cable must be used. For cable lengths over 100 feet (3 0meters), an in-line amplifier, semi-rigid coaxial cable, or other low-loss cable assembly must be used. See the table of accessories and spare parts in your receiver's *User Guide* for specifics.

### A.8.8 Compact Dome Antenna

The Compact Dome Antenna is a light-weight single-frequency antenna intended mainly for use on rovers. It is fully weatherproof, making it particularly suitable for marine applications (although not for airborne applications). It is appropriate for the static, kinematic, and RTK surveying procedures.

**Setup and height measurement.** Use the procedures described in the sections Tripod with Tribrach and Rangepole.

Since the antenna has no groundplane, you must measure its corrected height when it is mounted on a tripod. This limits the accuracy of the height measurement. For that reason, among others, this antenna is not recommended for control surveying applications with high precision requirements.

**Care.** The Compact Dome Antenna is fully weatherproof, and requires no maintenance. It is designed for field use under rough conditions, but it is a precision instrument; treat it with reasonable care.

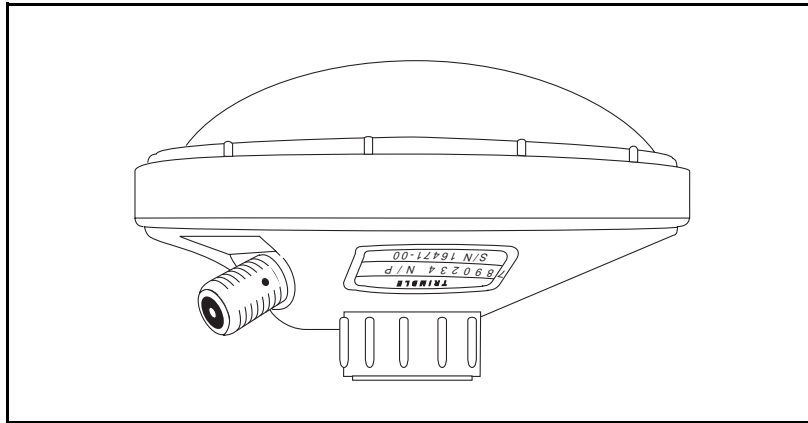

**Figure A-6. Compact Dome Antenna**

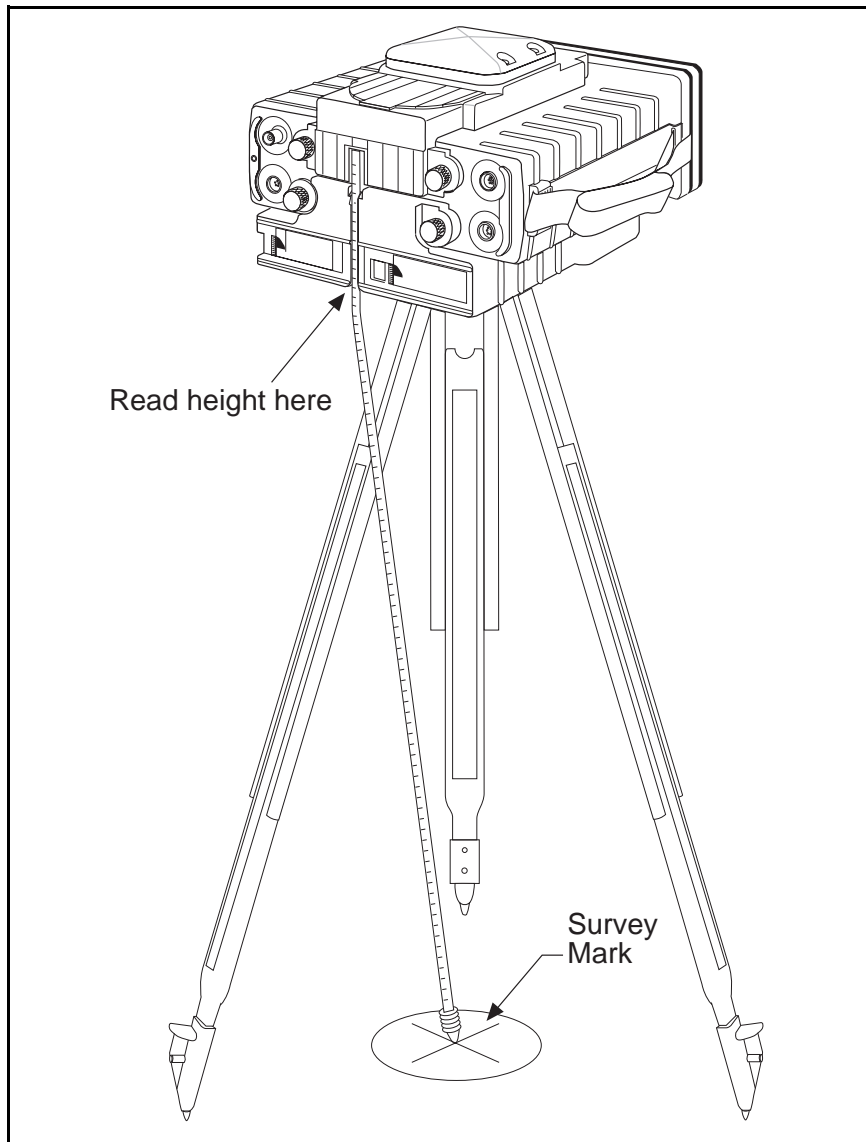

**Figure A-7. Modular Antenna**

### **A.8.9 Modular Antenna**

The Modular Antenna is a single-frequency antenna intended for use in static surveys only. It is used primarily with the 4000SE, but is compatible with other receivers as well.

The Modular Antenna is designed to be mounted directly on a portable receiver, which is mounted in turn on a tripod and tribrach. The antenna, receiver, and tripod form a single unit which is easier to carry and set up than a separate antenna/tripod and receiver would be. This antenna can be used only in conjunction with a Battery Module, which is involved in the procedure for measuring antenna height.

#### **Setup.**

1. Set up the tripod over the survey mark.

The top of the tripod should be roughly at eye level. This makes adjustment easier, and also reduces the risk of signal interference from near-by vehicles, your head, or other objects.

The antenna, when mounted, must have a clear line of sight to the satellites it will track during the survey. For suggestions on dealing with marginal visibility, see the section Entering Antenna Parameters.

2. Mount the tribrach base on the tripod.
3. Use the optical plummet as a guide to center the tribrach base over the survey mark. Level the tribrach. Check the optical plummet to be sure the tribrach is still centered; if it is not, recenter it and relevel it. Continue to check and adjust until the tribrach is both centered and leveled.
4. Attach the Modular Antenna to the top of the receiver, the Battery Module to the bottom of the receiver, and the tribrach adapter to the bottom of the Battery Module.

The Battery Module and Modular Antenna each have tabs that slip into slots behind the receiver's front panel. When one of the units is correctly seated, the two setscrews on the back may be tightened to hold it firmly in place. Its electrical connectors automatically make contact with the appropriate ports on the back of the receiver.

5. Seat the tribrach adapter on the tribrach base and clamp it in place.

### **Height measurement.**

Pull the measuring tape down from the back of the Modular Antenna. With a slight twisting motion, thread it through the guides on the back of the Modular Antenna and on the back on the Battery Module.

To measure the antenna's height, pull the antenna tape down to the survey mark. Read the antenna height at the lower edge of the antenna guide on the bottom of the Battery Module. (See Figure A-7.) This is the antenna's *uncorrected* height.

### **A.8.10 Compact L1/L2 Antenna**

This antenna is intended for use in all types of surveys, but particularly surveys that require dual-frequency operation, such as FastStatic surveys and long-baseline static surveys. It can be fitted with a groundplane for control surveys and other projects where multipath interference must be minimized, or it can be used without the groundplane for mounting on a rangepole.

**Attaching the groundplane.** The antenna and groundplane are held together by eight setscrews on the underside of the groundplane.

To attach the antenna to the groundplane, seat it in the hole in the groundplane's center. Note the post in one corner of the mount hole near the north arrow; it fits into a hole on the base of the antenna, so that the antenna will fit in only one orientation.

When the antenna is properly seated, tighten one setscrew on each side; then tighten the other setscrew on each side.

**Setup and height measurement.** Use the procedures described in the sections Tripod with Tribach and Rangepole.

Note that the antenna itself has notches that may be used for measuring antenna height by the direct method when the groundplane is not being used. The dimensions of the antenna and of the groundplane are printed on the groundplane, enabling you to compute the antenna's corrected height yourself whether or not the groundplane is attached.

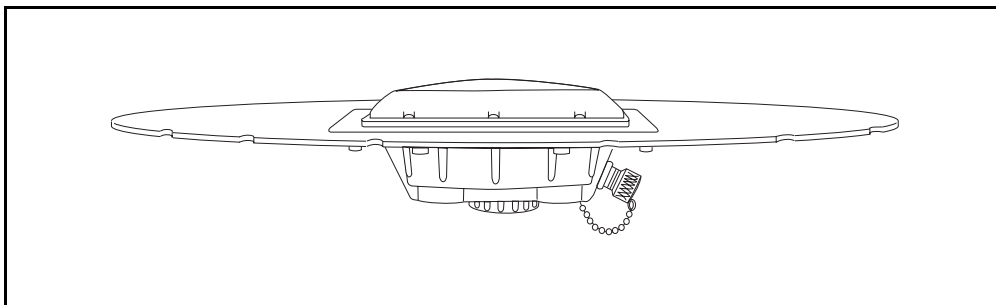

**Figure A-8. Compact L1/L2 Antenna with Groundplane**

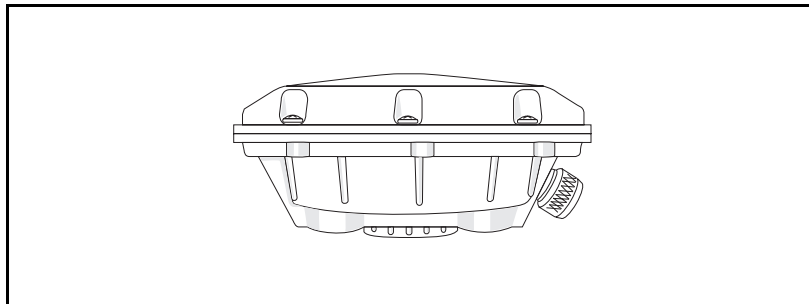

**Figure A-9. Compact L1/L2 Antenna without Groundplane**

**Care.** The antenna contains a desiccant pack to absorb moisture inside the unit. The desiccant pack screws into a plug which, in turn, screws into the base of the antenna.

There are several indicator dots (30%, 40%, 50%, and 60%) on the face of the desiccant pack. When the 50% dot changes from blue to pink, the desiccant must be replaced. You can obtain a replacement kit containing two new desiccant packs by contacting an authorized Trimble representative or the Trimble Service Department.



---

**Note** – Failure to replace a desiccant pack when the 50% dot changes to pink may result in damage to the antenna.

---

To replace the desiccant pack, unscrew the plug. Holding the plug face up, screw the old pack out of the plug and screw a new one in. Then screw the plug back into the antenna.

You may also dry and reuse the desiccant. Unscrew the plug from the antenna base and unscrew the desiccant pack from the plug, as above. Set aside the indicator card. Pour the desiccant onto a platter and dry it in a 300°F (140°C) oven for several hours, until its color changes from pink to blue. Let the desiccant cool, pour it back into the pack, reinsert the indicator card, and put the pack back into the antenna.



---

**Note** – Heat the desiccant only. The desiccant pack's plastic parts will melt if it is heated.

---

### A.8.11 Compact L1 Antenna

This antenna is intended for use in all types of single-frequency surveys. It is mechanically identical to the Compact L1/L2 Antenna, but it has a single-frequency receiving element. Like the Compact L1/L2 Antenna, it is available with or without a removable groundplane.



All of the comments on use and care of the Compact L1/L2 Antenna apply to this antenna as well.

#### **A.8.12 Permanent Reference Station L1/L2 Geodetic Antenna**

This antenna is electrically identical to the Compact L1/L2 Antenna, but is designed for permanent installation at sites that may be subject to hostile weather conditions. The groundplane is more heavily built and is permanently attached.

**Setup and height measurement.** For tripod mounting, use the procedures described in the section Tripod with Tribrach. For permanent mounting, measure antenna height by any appropriate method, such as measuring a baseline to another point whose coordinates are known.

**Care.** See the discussion of the Compact L1/L2 Antenna, above.

#### **A.8.13 L1 Geodetic Antenna**

This antenna is a predecessor to the Compact L1 Antenna. It is a high-precision microstrip antenna with groundplane for single-frequency static surveying.

**Setup and height measurement.** Use the procedures described in the section Tripod with Tribrach.

**Care.** See the discussion of Compact L1/L2 Antenna, above.

### A.8.14 L1/L2 Geodetic Antenna and L1/L2 Kinematic Antenna

These antennas are predecessors of the Compact L1/L2 Antenna with groundplane. Both are dual-frequency antennas. The L1/L2 Geodetic Antenna has a permanently attached groundplane; the L1/L2 Kinematic Antenna has no groundplane. The two are otherwise identical.

**Setup and height measurement.** This antenna is customarily mounted on a pole attached to a permanent structure such as a building. Its height is measured by any sufficiently accurate method such as direct physical measurement or triangulation. Measure the height according to the antenna's base and add the correction shown in Table A-3.

The procedures described in the sections Tripod with Tribach and Rangepole may also be used.

**Care.** See the discussion of the section Compact L1/L2 Antenna, above.

### A.8.15 4000ST and SST Kinematic Antenna

This is a single-frequency antenna intended primarily for kinematic surveys. It is a predecessor of the Compact L1/L2 Antenna without groundplane.



---

**Note** – This antenna is physically very similar to the L1/L2 Kinematic Antenna described above. It can be distinguished by the location of the antenna cable connector: on the side of the L1/L2 Kinematic Antenna, and on the bottom of the 4000ST and SST Kinematic Antenna.

---

**Setup and height measurement.** Use the procedures described in the sections Tripod with Tribach and Rangepole.

**Care.** See the discussion of the Compact L1/L2 Antenna, above.

## A.9 Site Preparation and Planning

If at all possible, plan the survey for a time when you will have continuous access to at least one satellite above the minimum required by the procedure you are performing. Two satellites above the minimum is better; three or more is even better. A reasonably low PDOP (no higher than 7, ideally 5 or less) is also important. Trimble produces two computer software packages, Plan and QuickPlan, which can help you predict satellite availability. Their features are similar except that Plan maintains a database of satellite availability, and QuickPlan does not. Both are available as components of the GPSurvey postprocessing package; QuickPlan is also available as a separate product.

When you visit a site to prepare for a survey, look for obstructions that could cause loss of lock. Poles or cables thicker than about 2cm ( $\frac{3}{4}$ " ) are liable to cause trouble; so is vegetation too thick to pass sunlight.

Note that solitary or widely spaced poles and cables are unlikely to cause problems *if several satellites more than you need are available*. Such obstructions will rarely block signals from more than one or perhaps two satellites at a time.

Remember that obstructions tend to cause loss of lock when they pass between an antenna and a satellite, not necessarily when they hang overhead. If the elevation mask is set at  $15^\circ$ , any obstruction whose elevation exceeds  $15^\circ$  is potentially a problem. In borderline cases, satellite elevation plots can help you identify obstructions that are liable to cause trouble.

If you are conducting a kinematic or RTK survey, for which rovers must maintain continuous lock, take care to avoid loss of lock while moving from mark to mark. If the most logical path between two marks passes too near an obstruction, note that fact during site preparation and find an alternate route. If the obstruction may prove impossible to avoid, prepare a reference mark where the rover can be reinitialized if necessary.

Site base stations with particular care. If a base station loses lock the survey will be invalidated, and if the station is unattended you may not even know there is a problem until you try to postprocess your data.

## A.10 Entering Antenna Parameters

Many procedures require you to enter antenna parameters: antenna height, antenna type, etc.

Some procedures automatically prompt you to enter antenna parameters. In these cases, start the procedure below at the appropriate step. In other cases, start the procedure at the beginning.

### To enter antenna parameters:

1. **At the beginning of a preplanned static survey.** The receiver prompts you for the antenna parameters automatically by displaying the antenna parameter screen. Go directly to step 4.
2. **During a static survey or data logging session.** Press the [ ] OG [ ] DATA key, if necessary, to display the survey status screen. Then go on to step 2.

```
SURVEY:                                | USER INPUT  
                                           |   CHANGES  
                                           |  
                                           | END SURVEY
```

3. **During a FastStatic or kinematic survey.** From the main survey screen, press the INPUT/CHGS softkey to display a screen similar to this one. Then go on to step 2.

```
FAST STATIC: |
              | USER INPUT
              |   CHANGES
              |   STATUS
```

4. **At the end of a survey** If you do not enter values for the antenna parameters during a survey, the receiver prompts you for them again when you end the survey by displaying the antenna parameters screen. Go directly to step 4.
5. Select CHANGES to display a menu similar to this one:

```
SURVEY CHANGES: | ANTENNA HEIGHT
                  | FILE NAME
```

6. Select ANTENNA HEIGHT to display a screen similar to this one:

```
ANT HEIGHT: 0000.0000 INCHES | UNITS
MEAS TYPE:  UNCORRECTED      | NEXT
ANT TYPE:  EXTERNAL (UNKNOWN) | NEXT
ANT SERIAL: 000000          | ACCEPT
```

7. Fill in the fields as appropriate. Press ACCEPT or [ENTER] to accept each one:
- ANT HEIGHT: The antenna height, expressed in the displayed units.

For procedures that use a tripod, it is necessary to set the antenna height each time the tripod is moved or adjusted. For procedures that use a rangepole it is generally necessary to set the antenna height just once, since moving a rangepole does not change its height.

To cross-check the antenna height, press the UNITS softkey to change the display from English to metric units, or *vice versa*. Remeasure the antenna height in the units now displayed. If your new measurement does not agree with the value displayed, reset the units, then measure and cross-check the antenna height again.

- MEAS TYPE: Set to UNCORRECTED or CORRECTED, as appropriate for the type of antenna you are using. (Trimble postprocessing programs can convert an uncorrected height to a corrected height.)
  - ANT TYPE: The type of antenna you are using (see Table A-4).
  - ANT SERIAL: The antenna's serial number. (This is not essential to the survey, but will help you identify the antenna you used if you later find that it was not working correctly.)
8. After you accept a value in the last field, the receiver returns to the main survey screen or other screen from which you began.

**Table A-4. ANT TYPE Parameter Values**

<b>ANT TYPE Value</b>	<b>Antenna</b>
EXTERNAL (UNKNOWN)	Unsupported or unknown
COMPACT L1/2 W/GRND P	Compact L1/L2 with groundplane
COMPACT L1/2	Compact L1/L2 without groundplane
COMPACT L1 W/GRND P	Compact L1 Antenna with groundplane
COMPACT L1	Compact L1 Antenna without groundplane
PERMANENT L1/L2	Permanent Reference Station L1/L2 Geodetic Antenna
INTERNAL (ST)	4000ST Integral Antenna (not applicable to receivers described in this manual)
ATTACHABLE (SE)	Modular Antenna
EXT COMPACT DOME	Compact Dome Antenna
EXT KIN (ST,SST)	4000ST and SST External Antenna
EXT L1/2 GEOD (SST/E)	L1/L2 Geodetic Antenna
EXT L1/2 KIN (SST)	L1/L2 Kinematic Antenna
EXT GEOD L1 (ST,SST)	L1 Geodetic Antenna

## A.11 Reading the Main Status Screens

The first main *Status* screen is displayed when you press the [STATUS] key, or when you press the [Cl EAR] key until the display stops changing. Additional screens are displayed by pressing the MORE softkey.

### A.11.1 Main *Status* Screen 1

The first main *Status* screen has three forms, depending on the receiver's current state.

- A static survey is running or a quickstart static survey waiting to begin:

```
0492-137-0 LOGGING FOR 0:01 |ELEV/AZM
APPROX. MEMORY LEFT: 94 HR |POSITION
SV[02,19,06,18] | DATE
PWR2+[_____] * 2:05:03 PST/24 | MORE
```

*Non-survey data logging uses the static surveying procedure. The receiver therefore displays this screen whenever a non-survey procedure is logging data.*

- No static survey is running and the receiver is computing RTCM-104 corrections (only with RTCM-104 Output Option):

```
RTCM-104 REFERENCE STATION |ELEV/AZM
GENERATING CORRECTIONS FOR |POSITION
SV12,13,20,24 | DATE
PWR1+[_____] * 00:24:14 UTC | OPTIONS
```

- No static survey is running and the receiver is computing position fixes:

```
POSITIONING - AUTO SV SELECT |ELEV/AZM
POSITION FIX: LAT/LON, FIX HGT |POSITION
SV12,13,20,24 | DATE
PWR1+[_____] * 00:23:26 UTC | OPTIONS
```

The lines of the screen show:

1. Receiver's current status (see Table A-5).



If a quickstart survey is waiting to begin or a static survey is running, this line also shows the name of the active data file and the time, in hours and minutes, that the receiver has been logging data.

2. If a static survey is running, the approximate capacity of the remaining free memory, expressed in hours of logging with the current parameters.

If the receiver is computing RTCM-104 corrections, the text 'GENERATING CORRECTIONS FOR'.

If the receiver is computing position fixes, the type of fixes.

3. SV numbers of the satellites from which data is being logged or used. Satellites that are being tracked but not used are not shown.

Satellite numbers inside square brackets are being used for survey measurements only. Satellite numbers outside square brackets are being used for position fixes and/or DGPS (and possibly also for survey measurements).

4. The current power source, power gauge, antenna symbol, time, and time zone identifier

The power gauge shows five blocks for a power supply or a fully charged battery. As the charge decreases, portions of the blocks progressively disappear.

A 'C' or 'P' appears after the power indicator if the battery charger (C) and power output (P) feature is enabled.

The antenna symbol, '⚡', appears if an antenna is detected on the ANTENNA port.

The time display does not show seconds if the receiver has not tracked satellites since power up or for many hours of operation.

**Table A-5. Receiver Status on Main *Status* Screen 1**

Type of Operation	Status	Meaning
Logging Data	WAITING FOR START	A preplanned session's start time has not arrived yet.
	WAIT: $n$ SVs $\geq$ MASK	The receiver is acquiring satellites. It must find $n$ healthy satellites above the session's elevation mask to begin logging data.
	PRE-SURVEY POSITION	The receiver is taking a position fix at the start of data logging as part of its record keeping.
	STARTED SURVEY	Data logging has started.
	LOGGING FOR $h:mm$	The receiver has been logging data for $h$ hours and $mm$ minutes.
Differential GPS base station	RTCM-104 REFERENCE STATION (or REFERENCE SURVEYOR)	The receiver is generating RTCM-104 corrections for use in differential GPS.
Differential GPS rover, or autonomous operation	POSITIONING -- AUTO SV SELECT	The receiver is computing position fixes, and is automatically selecting and tracking the most appropriate SVs.

### A.11.2 Main *Status* Screen 2

If a static survey is running or a quickstart static survey is waiting to begin, the first main *Status* screen displays a MORE softkey. That key displays a second screen in the main *Status* sequence, showing when the survey started or will start, and when it will stop. The format of the screen depends on the receiver's state.

- Quickstart survey or manual preplanned survey waiting to begin:

```
START WHEN:  SVs RISE ABOVE      |
              ELEVATION MASK      |
STOP WHEN:   SVs FALL BELOW      |
              ELEVATION MASK OR   |MORE
              USER END
```

- Quickstart survey or manual preplanned survey running:

```
STARTED AT:                                |PREV
          TUE 18-MAY-93 13:28 PDT/24      |
STOP WHEN:  SVs FALL BELOW                |
              ELEVATION MASK OR USER END  |MORE
```

- “At specified time” preplanned survey running:

```
START AT:                                |ELEV/AZM
          17:55 UTC                       |POSITION
STOP AT:  19:35 UTC                       |  DATE
                                                |  MORE
```

The lines of the screen show:

- 1-2. The time or condition at which the survey began or will begin.
- 3-4. The time or condition at which the survey will end.

### A.11.3 Main *Status* Screens 3 and 4

The third and fourth screens in the main *Status* sequence look like this:

	SU02	SU19	SU26	SU27	PREV
CONTINUOUS	36	79	80	80	
TOTAL MEAS.	80	80	80	80	
					MORE

LOGGING ELEV MASK:	+15'	PREV
LOGGING INTERVAL:	15.0 SEC	
MINIMUM NUM. SVs:	3	
LAST EVENT ID:	00000	MORE

**Screen 3.** The screen shows the number of measurements that have been made from each satellite being tracked. If the receiver is tracking too many satellites to describe on one screen, the MORE key displays additional screens to show the rest.

CONTINUOUS is the number of measurements made since the receiver started logging data to the current file. The count is reset if the survey is interrupted or if a cycleslip occurs. TOTAL MEAS is the total number of measurements made since the receiver started logging data to the current file.

**Screen 4.** The screen shows the parameter values being used to log data: the survey elevation mask, logging interval, minimum number of SVs required to log data, and the last event ID recorded in this file.

In both screens, the NEXT and PREV softkeys display the next and previous main *Status* screens.

## A.12 Restarting a Session After a Power Failure

### Static survey with auto-survey timer enabled.

1. Restore power to the receiver.
2. After the receiver completes its power-up test, it displays this screen:

```
AUTO-SURVEY MODE ENABLED
POWER FAIL?
STARTING SESSION: 1234-111-0
IN 30 SECONDS
```

When the countdown reaches zero, the session is restarted.

Data is logged to a new file with the same name as the original file. The files may be distinguished by their start times. When the data files are downloaded to a computer, the second file must be renamed to avoid a naming conflict. The files should be merged after the download is complete.

### All other procedures.

1. Restore power to the receiver.
2. After the receiver completes its power-up test, it displays this screen:

```
SURVEY RESTARTED

AFTER POWER FAIL
** PRESS ANY KEY **
```

3. To display the status screen or the main survey screen, as appropriate, press any key.

If you are conducting a roving procedure such as a kinematic survey or GIS data acquisition, it is prudent to reobserve a point that was successfully observed before the failure. This provides a “sanity check” on post-recovery results: if the second of these observations does not agree with the first, you will know something went wrong.

The receiver always returns to the state it was in when the failure occurred. In a FastStatic survey, for example, it may return to the *Static* state (collecting data) or the *Moving* state (waiting for the user to press START).

Data from the restarted session is logged to a new file with the same name as the original data file. (The receiver, unlike most computer file systems, allows files to have duplicate names.)



---

**Note** – If an interrupted survey or other data logging session is not allowed to restart in the field, it will attempt to restart the next time the receiver is turned on. In that case you must allow the survey to restart, then follow the standard procedure for ending .asurvey.

---

## A.13 Renaming the Current Data File

When the receiver creates a data file, it creates a name for the file according to rules described in the section How the Receiver and Programs Handle File Names.

The FILE NAME screen lets you change the name of a data file at any time while data is being logged to it. Press [L OG] [DATA] to display the SURVEY screen. Select CHANGES; then select FILE NAME. The receiver displays this screen:

```
CHANGE SURVEY FILE NAME: | ALPHA
      OLD: 0492-137-0    |
      NEW: 0492-137-0    |
                          | ACCEPT
```

OLD shows the file's current name. NEW initially contains the same value as OLD.

Edit the NEW field to show the name you want the file to have; then press [ENTER] or ACCEPT. You may press the ALPHA/NUMERIC softkey to toggle the receiver between alphanumeric mode and numeric mode.

## A.14 Enabling Cycle Printouts

A *cycle printout* is a real-time record of some aspect of a receiver's operation that is written to a serial port. Most types of cycle printouts consist of a series of one-line ASCII records, generated at the rate of one record per receiver cycle.

In practice, cycle printouts are rarely printed. More often they are recorded by a computer for later use, or are fed to an external device such as a navigation/positioning system. For this reason, most cycle printouts can be generated in binary format as well as ASCII format; a few of them can be generated only in binary format.

For information about connecting the receiver to a device that will process cycle printouts, see the section *Connecting a Serial Port to Another Device*.

**To control production of cycle printouts.** From the *Control* menu, select CYCLE PRINTOUTS. The receiver displays this screen:

```
PRINTOUT EVERY RECEIVER CYCLE
      POSITION CALCULATIONS  <-- NEXT
      FORMAT [ ASCII  ]    <-- CHANGE
      ENABLE [ OFF  ]     <-- CHANGE
```

The second line identifies a type of cycle printout. To cycle through the available types, press the NEXT softkey.

The first line shows the interval at which this cycle printout is produced—for most, but not all, EVERY RECEIVER CYCLE.

The third line shows this cycle printout's selected format, ASCII or BINAR . To toggle the format, press the FORMAT... CHANGE softkey (available only for cycle printouts that support both formats).

The fourth line shows which serial port is being used to output this cycle printout (PORT 1 through PORT 4, subject to the number of ports on the receiver). The value OFF indicates that this cycle printout is disabled. To cycle through the available values, press the ENABLE... CHANGE softkey.



---

**Note** – Remember to disable a cycle printout when you are done using it. Cycle printouts are not disabled automatically when the receiver is turned off.

---

**Types of cycle printouts.** The types of cycle printouts you can produce are:

- *Position Calculations:* Information about the position fixes that a receiver computes every measurement cycle in certain operating modes.
- *Navigation Calculations:* Information about the results of the navigation calculations for the selected waypoints.



- *Raw Measurements*: Unprocessed satellite data.
- *Nav Display Unit*: Data required to drive a Trimble Display Unit. The format and contents are the same as for *Position Calculations*.
- *Compact Measurements*: Satellite data in a compact format for efficient transfer to a computer.
- *Eph/Ion/UTC Data*: Ephemeris, ionospheric, and UTC data transmitted by the SVs.
- *Position Quality Stats*: Sigma values; estimates of error in position fixes. Available only with QA/QC Option.
- *Raw L1 Data Message*: Raw L1 measurement data for each SV.
- *Position Type 2*: Very similar to *Position Calculations*. Unneeded characters are omitted to make room for higher precision coordinates.
- *Navigation Type 2*: Very similar to *Navigation Calculations*. Unneeded characters are omitted to make room for higher precision coordinates.

For information about the format and contents of each cycle printout, see the *Receiver Reference*.

Note that some of these types of cycle printouts are available only on receivers that have certain options installed. See the *Receiver Reference* for details.

**Enabling multiple types of cycle printouts.** You can enable any number of cycle printouts at the same time. It is generally best to write each type to a different serial port, since it may otherwise be very hard to tell what type of printout a given record represents. If you do want the receiver to write two or more types of cycle printouts to the same serial port, study the record formats carefully to be sure you can deduce the type of each record in the output.

## A.15 Generating Single-Shot Printouts

Single-shot printouts are similar to cycle printouts, but are produced once, on demand. The available types of single-shot printouts are:

- *Broadcast Data*: The most recently decoded ephemeris and almanac for a specific satellite.
- *Ionospheric & UTC Data*: The most recently decoded parameters for the basic ionospheric delay model, and for the conversion from GPS system time to Universal Coordinated Time (UTC).
- *Satellite Elevation Plot*: A graph showing the elevation and azimuth of a selected satellite versus time for any selected UTC day.
- *Schedule Plot For All Sats*: A graph of visibility for all known satellites over any selected UTC day.
- *Receiver Setup Info*: A description of the receiver, its characteristics, its control settings, etc.

For information about the format and contents of each single-shot printout, see the *Receiver Reference*.

**To produce a single-shot printout.** Select PRINT/PLO from the *Sat Info* menu:

```
PRINT/PLOT:   ON PORT [ 2 ]  <-- CHANGE
              BROADCAST DATA <-- CHANGE
              FOR SV01    <--NEXT SV
                          **PRINT**
```

Set the parameters on the first three lines to describe the printout you want to produce, then press the PRINT softkey.

The first line shows the port to which printouts are written. Press the first CHANGE softkey to cycle through the available ports.

The second line shows the selected type of printout. Press the second CHANGE softkey to cycle through the available types.

The third line shows the selected satellite (for printout types that concern one satellite). Press the NEXT SV softkey to cycle through the available satellites.

## A.16 External Data Logging (Only with Memory Option)

*External data logging* means logging data on a computer. The usual data logging procedure, which stores data in a receiver's memory, is distinguished by the term *internal data logging*.

External data logging, like internal data logging, requires a receiver that has the Memory Option. However, the amount of data you can log is limited only by the amount of free space on the computer's disk, not by the amount of free space in the receiver's memory.

In addition to a receiver with the Memory Option, external data logging requires:

- A serial data cable such as Trimble P/N 18826 (for p or t1 or3 on a portable receiver), P/N 18827 (for po rt2 or4 on a portable receiver), P/N 14284 (for an OSM2's data connector), or P/N 14284 (for any port on a rack-mounted receiver).
- A computer running the IBM DOS or Microsoft MS-DOS operating system.
- A copy of Trimble's external data logging program, LOGS .

### A.16.1 How to Install LOGST

LOGST and the downloading program '4000' are distributed on a single diskette, which is shipped with the Memory Option, and with receivers that have a factory-installed Memory Option. To install both programs, start the computer that will be used to log and/or download data and:

1. Create a directory on the computer's hard disk named C:\DOWNLOAD.

```
C> md \download
```

2. Make \DOWNLOAD the current directory and copy all of the diskette's files into it.

```
C> cd \download  
C:\DOWNLOAD> copy a:*.*
```

### A.16.2 How to Start Using LOGST in the Shortest Possible Time

This section explains the basics of using LOGS . The following sections give more detailed instructions.

**Setting up the system** To prepare your system for external data logging:

1. Select an available serial port on the receiver and one on the computer. Disable all types of output on the receiver's serial port; also disable RTCM-104 input and output. For instructions, see the section Disabling RTCM-104 Input and Output and Other Outputs in Chapter 5.
2. Configure the receiver's serial port to a known baud rate and data format, with FLOW CONTROL set to XON/XOF . For instructions, see the section How To Configure a Serial Port.

If you have no reason to choose differently, Trimble suggests a baud rate of 38,400 (or the computer's highest baud rate, if that is less), and a data format of 8 data bits, odd parity, one stop bit. The instructions for starting LOGS , below, assume this data format.

3. Connect the receiver's serial port to the computer's serial port with the appropriate cable.

**Starting LOGST.** You must start LOGST *before* you make the receiver start logging data.

Make \DOWNLOAD the current directory and enter this command:

```
C:\DOWNLOAD> logst -f file -u 5 -p n -b r
```

Replace the words in italics with appropriate values:

- *file*: The path and file name of the file which LOGST should create to store logged data. Do not specify a filename extension; LOGST adds its own.  
  
Trimble recommends that you use the same file name the receiver would use if it were logging data internally. The receiver's naming rules are described in the section Renaming the Current Data File. Enter only the numerals, not the hyphens, to limit the file name to eight characters.
- *n*: The number of the computer serial port that is connected to the receiver: '1' for COM1, or '2' for COM2.
- *r*: The serial port's data rate, in hundreds of baud. For example, use '96' for 9600 baud, '192' for 19,200 baud, or '384' for 38,400 baud. Set the same baud rate that you set on the serial port at the receiver's end of the cable.

For example, to log data to a file named 00010030 in a directory named HYDRO on drive C, reading input from COM2 at 38,400 baud:

```
C:\DOWNLOAD> logst -f c:\hydro\00010030 -u 5  
-p 2 -b 384
```

To log data to a file named 00340081 in a directory named WEST on drive C, reading input from COM1 at 96 00baud:

```
C:\DOWNLOAD> logst -f c:\WEST\00340081 -u 5
```

(In this example the serial port defaults to COM1, and the baud rate defaults to 9600.)

**Data logging.** Start a survey or other data logging procedure on the receiver in the usual way. Because the computer is connected and is running LOGS , the receiver will send logged data to LOGST instead of logging it internally.

Note that external data logging is incompatible with use of the receiver's auto-survey feature.

**Stopping the program.** LOGST stops automatically when the data logging operation ends. You must start it again before you start another data logging operation. *This is also true if a data logging operation is interrupted, for example, by a power failure on the receiver. See the description of the --c command line option, below for more information.*



---

**Note** – Never stop LOGST by resetting the computer or turning it off. If you do that, you may lose some or all of the data that has already been logged.

---

### A.16.3 Command Line Options for LOGST

This section describes all of the options you can enter on the LOGST command line.

**--f** *d:pathname\filename*

**--a** *d:pathname\fileroot*

You must specify one of these options, but not both.

**--f** specifies the data file's drive name, directory name, and filename. The directory must exist before LOGST is run.

**--a** specifies the data file's drive name, directory name, and first four characters of the filename. LOGST completes the filename with a four-character code created from today's date.

Do not enter an extension with either option. LOGST automatically adds extensions to the data files it creates.

If you plan to use **--a**, set the computer's internal clock to the UTC date and time before you start logging data. This will ensure that the proper date is used to create file names.

**Examples:**

```
C> logst -f c:\hydata\00020150 ...
C> logst -a c:\res290\hrbr ...
```

The first example logs data to a file named 00020150.R00 in a directory named \HYDATA on drive C. The second example logs data to a file named HRBR $xxxx$  in a directory named \RES290 on drive C;  $xxxx$  represents a four-character code created from today's date.

**--n** *m*

**--s** *m*

You may specify either of these options, but not both.

Either option makes the program create a new data file for every *m* minutes of logged data. **--n** (for “new”) makes the program write header and ephemeris data at the beginning of every file, and **--s** (for “split”) makes it write header and ephemeris data at the beginning of the first file only

Both options create a unique name for each data file by incrementing the number in the extension. **--n** uses the extensions R00, R01, R02,. ... Similarly, **--s** uses the extensions S00, S01, S02,. ...

If you omit both options (or use either one with a value of 0), LOGST creates a single data file with the extension R00.

Both options are useful for long data logging sessions; they make LOGST create several small data files instead of one large one, making the data easier to move around and back up. Data files created with **n** are independent units; they may be postprocessed individually or combined into one big file for postprocessing. Data files created with **s** must be combined into one big file.

**Examples.**

```
C> logst ... -n 60 ...
```

```
C> logst ... -s 60 ...
```

The first example creates a new data file every 60 minutes, with a complete set of header and ephemeris data at the beginning. The second example creates a new data file every 60 minutes, but only the first file will have header and ephemeris data.

**--n *m***

Makes the program update the current data file every *m* minutes.

If you omit this option or use it with a value of 0, LOGST updates the current data file only when the computer's memory is full or when the data logging session ends.

If a power failure or computer malfunction causes LOGST to crash, you will lose any data logged since the current data file was created or last updated. Using **--u** with a reasonably small value will minimize the risk of data loss. The resulting overhead is generally small.

If you specify **--u** together with **--n** or **--s**, the value of **--u** must be smaller than the value of **--n** or **--s**.

**Examples.**

```
C> logst ... -u 5 ...
```

```
C> logst ... -s 60 -u 15 ...
```

The first example creates a single data file and updates it every five minutes. The second example creates a new (split) data file every 60 minutes and updates it every 15 minutes.

**--p *n***



Specifies the computer serial port that LOGST should use to communicate with the receiver. The value of *n* may be 1 or 2; it defaults to 1.

**Example.**

```
C> logst ... -p 2 ...
```

This example makes LOGST communicate with the receiver through COM2.

**--b *r***

Specifies the data rate for the computer serial port. The data rate is specified in hundreds of baud; for example, '--b 96' represents 96 00baud.

If you omit this option, it defaults to 96 (for 96 00baud).

**Examples.**

```
C> logst ... -b 96 ...
```

```
C> logst ... -b 384 ...
```

The first example configures the serial port to operate at 9600 baud. The second example configures it to operate at 38,400 baud. (Note that many older computers cannot run a serial port faster than 9600baud.)

**--x *dps***

Specifies the data format for the serial port.

*d* is the number of data bits per character. It may be **7** or **8**.

*p* is the type of parity. It may be **o** for *odd*, **e** for *even*, or **n** for *none*.

*s* is the number of stop bits per character. It may be **1** or **2**.

If you omit this option, LOGST configures the serial port to operate with 8 data bits, odd parity, and 1 stop bit.

**Examples.**

```
C> logst ... -x 8o1 ...
```

```
C> logst ... -x 7e1 ...
```

The first example configures the serial port to operate with 8 data bits, odd parity, and 1 stop bit. The second example configures it to operate with 7 data bits, even parity, and 1 stop bit.

**--c *m***

Causes LOGST to wait for the receiver to respond for *m* minutes when it is started. This is useful when you must restart an interrupted survey; it lets you start LOGST before the receiver is necessarily ready for operation.

When you use this option, LOGST creates a split file (as if the `--s` option were used) with an extension of T00. If `--n` or `--s` is actually specified, subsequent files have extensions T01, T02, T03, ...

If you omit this option or specify it with a value of 0, LOGST will immediately display an error message and exit if the receiver does not respond.

**Example.**

```
C> logst ... -c 2 ...
```

The example makes LOGST wait for two minutes for the receiver to respond.

**Note on rounding of time-value parameters.** All time values (represented above by *m*) are rounded up to a multiple of 5 minutes, except for the value of `--c`.

### A.16.4 Error and Status Displays from LOGST

If LOGST cannot communicate with the receiver, it displays an error message and exits. Fix the problem and start LOGST again. Be sure that the receiver is connected and turned on; check the baud rate, data format, and port number that you entered on the command line against the ones you are using on the receiver.

If LOGST does establish communication with the receiver, it displays its command line option settings in a status screen similar to this one:

```
LOGST : External Datalogger for the 4000S   Version 92.110
Active Options
Output Filename : C:\DATA\00020150.R00
File Update Interval : 1 minutes.
File Split Interval  : 0 minutes.
New File Time:       : 0 minutes.
Communications Port  : 1
COM Port Parameters: : 9600 8-ODD-1
Establishing Communications with the 4000S
Communication with the 4000S successful
Seconds since last communication:      1
```

### A.17 Downloading Logged Data

After you finish one or more data logging sessions, you must *download* the resulting data files to make them accessible to a postprocessing program. Then you must delete the original files to free space for logging more data.

The procedure for downloading data depends on the postprocessing program you will use. Many postprocessing programs have built-in downloaders. This section describes '4000', a downloading program that Trimble provides for use with postprocessing programs that do not have their own downloaders.

### A.17.1 What '4000' Does

For internally logged data, 4000 actually copies data files from the receiver's memory to the computer's disk. It also reformats the contents of each file and splits it into four separate files containing different types of data. These files all have the same filename, and are distinguished by different extensions.

Externally logged data must also be downloaded. Even though the data files are already on the computer's disk, they must be reformatted and split into sets of four files, just like internal data files. The procedures for downloading internally and externally logged data are essentially the same.

### A.17.2 How to Install the Downloading Program

For instructions, see the section How to Install LOGST.

### A.17.3 How to Get Started with the Downloading Program

**Setting up the system (required only to download internally logged data).** Follow the system setup instructions given in the section How to Start Using LOGST in the Shortest Possible Time.

**Starting the downloading program.** Enter the command:

```
C:\DOWNLOAD> 4000 [ENTER]
```

The program displays a screen similar to this one:

```

TRIMBLE NAVIGATION          MODEL 4000S  SURVEY REPORT

                                <Press F1 for Help>
>1: DOWNLOAD SURVEY DATA (Receiver)  2: PROCESSING OPTIONS [menu]
3: DOWNLOAD SURVEY DATA (Dataowner)  4: Transfer to PC      [menu]
5: Data Analysis [menu]                6: Transfer from PC   [menu]
7: Station/Session Tables              8: 4000S Directory
9: PC Disk Directory                   ESC to DOS

Input option number or use arrow keys then ENTER

```

**Downloading: internally logged data.** Press the [1] key. The first time you do it, the program displays this screen:

```

TRIMBLE NAVIGATION          MODEL 4000S  SURVEY SUPPORT

                                VERIFY SERIAL PORT PARAMETERS

COM: 1  Baud:  9600  Data: 8  Parity: Odd  Stop: 1

+-----+
* F1 - Help          SPACE - Toggle          F10 - Accept *
+-----+

```

The cursor is at the serial port number, following COM. Press the space bar until the program displays the number of the serial port that is connected to the receiver. Press [TAB] or [SHIFT]+[TAB] to move right or left to the other fields, and set them to the baud rate and data format being used by the receiver's serial port.

When all of the fields are set correctly, press [F10] to configure the serial port and make the program display the next screen.

Note that the program will display the serial port configuration screen only the first time you download a file after starting the program.

**Downloading: externally logged data.** Press the [3] key. The program prompts you to enter the pathname where the logged files can be found. Enter the pathname and press [ENTER].

**Selecting files.** The program displays a list of logged data files, oldest first, with each file's name, size in records, and date and time created. If there are too many files to fit on the screen, you can display different parts of the list by pressing the [PgUp], [PgDn], [↑], and [↓] keys.

You can toggle the order of the file list from oldest first to newest first and back by pressing the [F3] key.

At any time, one line on the display is preceded by a '>'. Select the files you want to download by moving the '>' to each one and pressing the space bar. The program highlights each file you select. To deselect a selected file, move the '>' to it and press the space bar again.

To select all files, press [F9]. To deselect all files, press [F9] again.

**Downloading selected files.** To select the disk and directory where you want to store downloaded files, press [F2]. The program prompts you to enter the drive name and the directory's pathname. Press [ENTER] when done. If the directory does not exist, the program will create it.

Now press [F10]. The program reminds you to be sure the disk has enough free space to download the selected files. Press any typing key to start the download.

The program displays the name of each file as the file is downloaded. It also displays the record counts and the SV numbers of each file's satellite measurement data as it downloads.

The program displays a completion gauge at the bottom of the screen which shows the download's progress. The download is complete when the gauge reaches the right end of its scale.

You can interrupt a download at any time by pressing [Esc]. The download program will not save the partially processed download files on the disk.

**After a download.** When a download is complete, the program returns to its menu. You may select and download more files, or press [Esc] to exit the program.

Once you are sure that the logged data has been downloaded successfully, you should delete the original data files to free up space for more data logging.

To delete internally logged data files, select LOGGEDDATA FILES from the *Control* menu. This displays the SURVEY DATA FILES screen, whose DELETE softkey lets you delete files from memory.

To delete externally logged data files, use DOS's DEL command.

#### **A.17.4 How the Receiver and Programs Handle File Names**

**How internal data files are named.** A data file created in the receiver by internal data logging has a name with the format *ssss-eee-n*.

When the receiver creates a data file for a preplanned static survey, *ssss* is the ID of the station description used to schedule the survey, and *eee-n* is the ID of the session description used.

When the receiver creates a data file for any other type of survey, *ssss* is the last four digits of the receiver serial number, *eee* is today's day of year, and *n* is a digit that is incremented for each new session on a given day, beginning at zero.

Note that in either case, you can rename the data file while data is being logged. In that case it has whatever name you gave it.

**How external data files are named.** You specify an external data file's name with a command line option when you run the external data logging program, LOGS . The name may be any one- to eight-character sequence that obeys DOS file naming conventions.

The program does not let you specify an extension; it adds an extension to each file name according to these rules:

- If LOGST was run with the `thes-`(split) option, the first file it creates has the extension S00, and subsequent files have the extensions S01, S02, S03,. ...
- If LOGST was *not* run with the `thes-`option, the first file it creates has the extension R00. If it was run with the `then-` (new) option, subsequent files have the extensions R01, R02, R03,. ...
- If LOGST was run with the `thee-`option, it checks the disk for files with the same filename. If it finds any, it assumes that an interrupted session is being restarted, and it creates files with the extension Tnn, where *nn* starts at the first unused number. That is, if there are no files with the same file name and Tnn extensions it creates one with the extension T00; if there is a T00 it creates one with the extension T01; and so on.

If LOGST was run with the `thee-`option and finds no files on the disk with the same filename, it names the files as if `the-`was not specified.

**How downloaded files are named.** The download program, '4000', splits each logged data file into four download files, each containing different types of data.

All of the downloaded files share the filename of the logged data file (with the hyphens removed, if it is an internal file).

Each downloaded file has a distinct extension which identifies the kind of data it contains:

- DAT contains all data collected and generated during the logging period.
- MES contains an ASCII summary of the logging session. It contains the serial number of the receiver, the file name, logging start and stop times, and important parameter values.
- EPH contains ephemeris data.



- ION contains ionospheric and error correction data. It currently is not used by the postprocessing programs.

If the download program finds identically named files already on disk, it creates files with the extensions D00, M00, E00, and I00. This ensures that each downloaded file's name remains unique. If the program also finds files with those extensions on disk, it creates files with the extensions D01, and so on.

For example, if the program downloaded a file named 0002-015-0, it would name the resulting DOS files 00020150.DA , ...MES, ...EPH, and ...ION. The second time it downloaded the same file, it would name the resulting DOS files 00020150.D00, ...M00, ...E00, and ...I00. The third time, it would name the DOS files 00020150.D01, ...M01, ...E01, and ...I01, and so on.

If the program finds downloaded files already on disk, it displays this warning message:

```
DUPLICATE FILE NAMES ENCOUNTERED,  
ENSURE FILES ARE NAMED PROPERLY.
```

If you see this message, find the duplicate files and rename them so that the set you want to keep has the extensions DAT, MES, EPH, and ION. You may rename or delete the other sets, as appropriate. If you need to keep several sets of files, give the members of each set a unique filename; then change the extension of each member of each set.

### A.17.5 The “Disk Full” Condition

If you try to perform a download and the disk does not have enough free space to complete it, the program will display this message when the disk becomes full:

```
DISK FULL OR DISK WRITE ERROR - X RECORDS TRANSFERRED
```

*x* is the number of records downloaded before the disk filled up.

Erase some unneeded files to release enough space to complete the download, or insert another disk with sufficient free space. Also erase the files that the download program was creating. Then restart the download.

### A.17.6 Merging Split Files and Duplicate Files

To merge split data files created by LOGST, simply concatenate the files into a single new file in the order they were created. This example shows how you might concatenate a series of three data files that were created with the `s`-option:

```
C:> copy /b 00550233.s00 + 00550233.s01 +  
          00550233.s02      00550233.r00
```

The same technique works with files created with the `--n` option (extensions R00, R01,...), but you should *not* give the merged file the extension R00; it would then overwrite the original R00 file. Use a free *Rnn* number instead. If you are merging files with extensions R00 through R03, for example, give the merged file the extension R04. Since every *Rnn* file has a header, the merged file will be larger. The redundant headers create no problem for a postprocessing program, though.

The same technique works for duplicate files downloaded by the '4000' program. Merge files with extensions D00... D03 into one with extension D04, and so forth.

The batch file RECOMB.BAT, on the same distribution diskette as LOGST and 4000, merges up to 24 . *Snn* files into one . R00 file. This example merges up to 24 files named 00550243.S00, 00550243.S01,... into one file named 00550243.R00:

```
C : > recomb 00550243
```



## B Troubleshooting Guide

---

### **Receiver does not turn on:**

1. Check the power supply cable. Are both ends securely inserted?
2. Check the power source. Is it delivering DC to one of the receiver's power connectors?
3. Try another power source if one is available.
4. Check the in-line fuses.

### **No communication between receiver and computer or modem:**

1. Be sure that the data cable is connected to the proper ports on the receiver and the remote device (the computer or modem). Also be sure you are using the right cable. Different remote devices may require differently wired cables, even though the connectors may be the same at both ends. For specifics, see "Choice of Data Cable" on page 150.
2. Generate a one-shot printout on the affected receiver port. If the remote device is a modem, its DATA light should flash as the receiver generates the report. If the device is a computer, run a terminal emulator or other program that displays the affected port's serial input; the printout should appear on the screen as the receiver generates it.

If the modem's DATA light flashes or the printout appears on the screen, data is getting through to the remote device. Look for a problem that prevents the data producer from generating data, or the data consumer from making appropriate use of it. This might be an incorrect parameter setting in the receiver's CYCLE PRINTOUTS screen, or incorrect configuration in a program on the computer, for example.

If the modem's DATA light does not flash, or no printout appears on the computer's screen, data is not getting through to the remote device. Go on to the following steps.

3. If CTS/RTS flow control is *not* being used, be sure that the cable's RTS/CTS data lines are *not* connected. If CTS/RTS flow control *is* being used, be sure that the CTS/RTS data lines *are* connected, and that the external device drives RTS properly. RTS should be asserted whenever the device is transmitting data.
4. Be sure that the baud rate and data format parameters are set to the same values for the receiver and for the computer or modem, and that the intended type(s) of data input/output are enabled on the proper receiver/remote ports.
5. Restart the computer or modem; restart the application program you are running on the computer. If this does not work, try turning the computer off momentarily, then restart the computer again.

**RTCM data link problems and other serial port problems:**

The base station appears not to be transmitting RTCM data:

1. Check the *Status* display. It should say GENERATING CORRECTIONS FOR SVs.. .. If it does not, be sure that RTCM output is ENABLED and that all healthy satellites are ENABLED.

Also check the reference position. A common error is to enter the sign of the latitude or longitude incorrectly—for example, to enter E instead of W, or S instead of N. The receiver may not be able to track SVs if the position is wrong.

2. Check all of the cabling and digital communication settings as described in the preceding section.
3. Be sure that the external device is not trying to send status information back to the receiver. The receiver ignores most input. However, an XOFF code (hexadecimal 13) will suspend RTCM output until an XON code (hexadecimal 11) is received, or until the XOFF times out. The timeout period is 60 seconds.
4. For a radio communication link, be sure that the transmitting and receiving ends are set to the same data rate and format. This is not the same as the baud rate and data format between the receiver and the modem. The radio's data rate is the RF transmission rate in bits per second (50bps, 4800bps, etc). The data format is the modulation method (AM, FM, etc.) and the error correction method (FEC, CRC, etc). Modems from different manufactures may have different proprietary data formats; in that case they will not work together.
5. Be sure that the modem connected to the transmitter is not trying to transmit data at a higher RF data rate than the radio allows. Depending on the radio frequency used, standard radio links can handle rates of 50 to 4800bits/second.

A DGPS rover is not computing corrected position fixes or is not computing position fixes at all:

1. If the receiver is receiving RTCM data but is not computing position fixes:
  - a. Be sure that RTCM INPUTS is set to ON or ON/AUTO. If RTCM PORT is set to the port where corrections are being input, and ENABLE is set to OFF, the receiver will display corrections but will not use them.

- b. Check the UDRE values of the incoming data. The receiver will not utilize a differential correction whose UDRE (as displayed in the RTCM data screens) is 5 for RTCM Version 1.0, or 3 for RTCM Version 2.0.
  - c. Be sure that STATION ID is set to ANY or to the station ID that is found in the incoming data.
  - d. Be sure that the corrections being received are for the same set of satellites that you are tracking on the STATUS AZM/ELEV screen. If they are not, check the elevation masks and the enabled SVs on both the rover and the base station.
  - e. If none of this works, let the rover acquire a new ephemeris by tracking satellites for about 10 minutes with RTCM turned off. If the rover does not have the same IODEs as the base station (as displayed in the RTCM data screens) it will not use the corrections.
2. If the rover is not receiving RTCM data:
    - a. Be sure that RTCM input is being read from the proper port.
    - b. Be sure that no cycle printouts are directed to the same port. If the radio being used is a transceiver, this may cause the radio to transmit the printouts, interfering with reception.
    - c. Check all of the data link parameters for the modems, radios and rover

**Incorrect/inaccurate survey results or position fixes, or high PDOP:**

1. Be sure L2 P-code processing is enabled on all channels if you are using a procedure that requires it. Be sure that per-channel configuration is not in use. (See “Configuring Single or Dual-Frequency Operation” on page 156.



2. Be sure the applicable sync time parameter is set to a value that is appropriate for the procedure you are using. If you are conducting a survey, be sure you are performing the surveying procedure correctly; be sure you are occupying each survey mark for the required minimum time.

**One or more space vehicles are untrackable:**

1. Check the azimuth and elevation of the SV and be sure there are no obstructions in the path of the satellite signals.
2. Check the elevation mask to make sure that the SVs you want to track are not masked.
3. Be sure that none of the SVs you want to track are disabled.
4. Press [SAT] [INFO] to check the health of the satellites. If any of the SVs you want are unhealthy, use the SV ENABLE/DISABLE screen to set them to IGNORE HEALTH (POSITIONING) or IGNORE HEALTH (SURVEYING), as appropriate.
5. Recheck the receiver's antenna connections.
6. Reposition the GPS antenna above any nearby transmitting antennas if possible.

**Bad real-time positions from DGPS:**

1. Check the PDOP on the POSITION screen. A PDOP near 7.0 yields moderate position accuracy. A PDOP of 7 or more yields position fixes that are too inaccurate to be useful for most purposes.
2. Check for an unhealthy satellite being used. Signals from an unhealthy satellite can produce bad position fixes by introducing errors into the calculations.
3. Be sure the receiver is operating as a DGPS rover. If it is operating autonomously it will produce uncorrected position fixes, whose accuracy is significantly lower.

**Receiver does not operate or behaves oddly:**

When using the 4000A/S COMPATIBLE remote protocol, the receiver may interpret improperly formatted input data as remote commands. These commands could corrupt the internal database and cause the receiver to operate poorly or not operate at all.

Most often the problem is caused by a mismatch between the baud rate or data format of the receiver's serial port and the other device. Even valid commands will be received incorrectly if the baud rate and format are wrong. The same symptoms can be caused by inputting RTCM data on a port that is not configured for RTCM input.

To correct the problem

- a. Disconnect the data source from the receiver serial port.
- b. Power the receiver down and back up.
- c. Be sure that the baud rate and data format parameters are set to the same values at both ends of the connection.

If this does not correct the problem, see "When all else fails."

**Asset Surveyor, Survey Controller, or Seismic Controller does not communicate with receiver:**

1. Be sure that the receiver's serial port is set to 9600 baud, with data format 8-NONE-1.
2. Be sure the receiver's protocol set to DATA COLLECTOR.
3. Be sure the data collector's serial port is set to 9600 baud.
4. Be sure the serial data cable is firmly attached to the ports on the data collector and the receiver.
5. Remember that when the receiver is conducting a kinematic survey, it must be receiving data from four satellites before the data collector can be started.

**When all else fails:**

1. Use the *Control* menu's DEFAULT CONTROLS screen to reset the receiver's factory default parameter values.
2. As a last resort, perform a hard reset on the receiver:
  - a. Turn off the receiver.
  - b. Hold down the [C] [E] [A] [R] and [L] [O] [G] [D] [A] [T] [A] keys and press the [P] [O] [W] [E] [R] key.
  - c. When the TEST MENU SETUP/CONTROL screen appears, release [C] [E] [A] [R] and [L] [O] [G] [D] [A] [T] [A].
  - d. Press the CLEAR ALL softkey.

This procedure resets the memory that the receiver uses for operations; it does not delete data logged to the memory board.

**How to get technical support:** If you cannot resolve your problem without assistance, contact the Trimble Assistance Center (TAC). Refer to the Preface to this manual for information on contacting the TAC.

Assistance is also available through Trimble's Customer Support Bulletin Board System (BBS). The BBS is normally available around the clock, although Trimble support personnel are not necessarily available at all times. refer to the Preface to this manual for information on accessing the Customer Support BBS.



# Index

---

## Numerics

1 PPS OUT connector A-3  
1 PPS Output Option A-2, A-3  
12 VDC IN connector A-2  
4000 A/S Compatible protocol A-9  
4000 downloading program A-71  
4000SE Land Surveyor 4-12  
4000SSE Land Surveyor II DA-12  
4000ST and SST Kinematic  
Antenna A-46

## A

ANT HEIGHT parameter A-49  
Antenna  
    Fast Static survey 3-2, 3-11  
    Height corrections, table of A-34  
    Height measurement A-23, A-30  
    Kinematic survey 4-19, 4-20, 4-21, 4-22  
    Parameters, entering A-48  
    Positioning parameters 2-33  
    Quick-release adapter and bayonet A-35  
    Radio 5-17  
    Range pole A-30

Static survey 2-2  
Static survey parameters 2-9, 2-25, 2-26, 2-30  
Status screen indicator for A-53  
Table of applications and procedures 1-10  
Use and care A-22  
Antenna cables A-38  
ANTENNA connector A-3  
Antenna swap technique for initializing kinematic survey 4-12, 4-15  
Any Day at Specified Time session 2-19, 2-26, 2-29, A-55  
Applications 1-2, 1-3, 1-9, 1-10  
Asset Surveyor 7-2, A-31, B-6  
audience xvii  
Auto-survey timer 2-28, 2-31, A-57  
AUX connector A-2, A-7

## B

Backpack Antenna Mount A-38  
Batteries A-3, A-53  
Battery Module A-4, A-41  
Broadcast Data single-shot printout A-62  
Bulletin board systems (BBSs) 1-12

**C**

Camcorder batteries A-3  
 caution xxxii  
 Characteristics of GPS Procedures  
 1-5  
 Comments for event marks A-16  
 Compact Dome Antenna A-38  
 Compact L1 Antenna A-44  
 Compact L1/L2 Antenna A-30, A-42  
 Compact Measurements cycle  
 printout A-61  
 Connector A-2  
 Continuous kinematic survey 4-1, 4-21  
 Control survey 1-5  
 copyright iii  
 Corrected height of antenna A-34, A-42  
 Corrections for DGPS 5-1  
 Cross-track error 6-10, 6-11  
 Cycle printout A-59

**D**

DAT file name extension A-76  
 Data Collector Compatible protocol A-9  
 DATA I/O PORT connectors A-2, A-6, A-7  
 Data logging  
 Differential GPS 5-18  
 Downloading data A-71  
 Effect on other operations 5-19  
 Entering supplementary data A-13  
 External A-63

External A-74, A-75  
 Internal, Memory Option  
 required for 5-5  
 Main Status screen A-52  
 Parameters 4-11  
 Static surveying procedure used  
 for 2-4  
 Types of data logger 2-7  
 Date, local time & time zone display A-19  
 DATM4000 program A-21  
 Datum 6-4, A-20  
 Default Control A-12  
 Default control A-10  
 DeltaNav QC quality control  
 program 5-4  
 Desiccant in antenna A-44  
 DGPS (Differential GPS)  
 GIS data acquisition uses 7-2  
 Procedure for 5-1  
 Static surveying at same time  
 as 2-34  
 Troubleshooting B-3, B-5  
 disclaimers iii  
 Dnn file name extension A-77  
 document conventions xxxi  
 DOPs, displaying 6-3  
 Downloading logged data A-8, A-76  
 Dual-Frequency Option  
 Compact L1/L2 Antenna A-42  
 Configuring A-12  
 L1/L2 Geodetic and L1/L2  
 Kinematic Antennas A-46  
 Permanent Reference Station L1/  
 L2 Geodetic Antenna A-45  
 Procedures requiring A-12

Static survey y1-5, 2-1

## E

Eastin g6-5, A-20  
 EchoXL Remote Display 5 -23  
 ELEVATION MASK parameter  
     FastStatic survey 3-6  
     Kinematic survey 4 -12  
     Positioning g2-34, 5-7, 6-5  
     Static survey y2-7, 2-21, 2-34  
 Enn file name extension nA-77  
 EPH file name extension A-76  
 Eph/Ion/UTC Data cycle printout tA-61  
 Ephemeris A-67, A-76  
 Event mark data A-15  
 EVENT MARKER connector A-3  
 Event Marker Input Option A-2, A-3,  
     A-15  
 EXT REF connector A-3  
 External data logging nA-74, A-75  
 External Frequency Input Option nA-3

## F

FastStatic survey A-12  
     Antenna parameters A -49  
     During kinematic survey 4-25  
     Entering supplementary data A-  
     14  
     Procedure e3-1  
 FaxBack xxi  
 Field notes A-17  
 File  
     Downloading logged data A -71

External data logging A-65

FastStatic survey 3-17

How named 2-26, A-75

Renaming current tA-58

Fixed baseline technique for kinematic  
 survey initialization 4-5, 4-13, 4-25

Fixed-height tripod A-30

Four Serial Port Option nA-2, A-4, A-6

Fuses, changing gA-4

## G

GIS data acquisition n1-8, 7-1, A-38  
 GPS ANTENNA connector A-3  
 GPSurvey postprocessing program 3-2  
 Groundplane A-22, A-45

## H

Height, antenna parameters 2-25, 2-26

## I

I/O 2 connector A-2, A-5  
 Inn file name extension nA-77  
 ION file name extension A-77  
 Ionospheric & UTC Data single-shot  
 printout tA-62  
 Ionospheric data A-77

## K

Kinematic alarm 4 -27  
 Kinematic survey  
     Antenna parameter sA-49

## Index

---

Defined 4-1  
Entering supplementary dataA-14  
Initialization 4-12, 4-18, 4-25  
Multiple base station s4-6, 4-18  
Observation procedure4-4  
Planning 4 -5  
Reference mark precision4-5

## L

L1 Geodetic Antenna A-45  
L1/L2 Geodetic Antenna A-30, A-46  
L1/L2 Kinematic AntennaA-46  
L1/L2 PCode OptionA-12  
Leapfrog kinematic survey4-1  
Leg line 6-7, 6-14  
External data logging A -63  
Local datum and local zone6-4, A-20  
Local Datum/Zone Pos cycle printoutA-21  
Log Data screen2-33, 5-20  
LOGST data logging program A -63  
Loss of lock in kinematic survey  
Base station 4-27  
Kinematic alarm signal s4-24  
Multiple base stations help prevent 4-18  
Reinitialization4-22, 4-24  
What can cause A-47

## M

Magnetic mount for an antennaA-36  
Main Status screen

Data logging, effect of5-19  
During static survey2-33  
Interpreting A-51  
Power gaugeA-3  
Manual Start by User session2-19, 2-26  
Mark ID for FastStatic survey 3-11  
Maxwell technology 1-7, 5-1, 6-1  
MEAS SYNC TIME parameter  
FastStatic survey 3-6  
Kinematic survey 4-12  
Positioning 5 -7  
Static survey 2-7, 2-21, 2-34  
Measuring rod, how to useA-24  
Memory Option 5-5  
Memory, resetting B-7  
MES file name extensionA-76  
MIN SVs parameter 2-21, 4-12  
Mnn file name extensionA-77  
Modular AntennaA-41

## N

Nav Display Unit cycle printoutA-61  
Navigation 1-8, 6-1, 6-2  
Navigation Calculations cycle printoutA-60  
Navigation Package Option 6-1, 6-7  
Navigation Type 2 cycle printout A -61  
NAVSTAR system, information about 1-12  
Network survey 2-9, 3-7  
Northing 6-5, A-20  
notes x xii



**O**

Once at Specified Date and Time  
 session 2-20, 2-26, 2-29, A-55  
 Optical plummet tA-22  
 organization xviii  
 OSM2 (Office Supply Module)A-1, A-6, A-7  
 Overdetermined position fix 6-4

**P**

PDOP MASK parameter  
 Choosing a value 5-7  
 Differential GPS, applies only to rovers 5-6  
 Navigation screen displays 6-5  
 Surveying parameter 2-34  
 PDOP, displaying 6-3  
 Permanent Reference Station L1/L2  
 Geodetic Antenna A-45  
 PFINDER postprocessing program 5-4, 7-5  
 Plan computer software A-47  
 Planning a survey 4-5, A-47  
 Point ID for kinematic survey 4-6, 4-14, 4-19  
 Position Calculations cycle printout tA-60  
 Position fix  
 Differential GPS base station does not calculate 5-20  
 High PDOP suppresses 5-7  
 Logging 2-18  
 Main Status screen displays type A-52

Overdetermined 6-4  
 Position Calculations cycle printout tA-60  
 Position Quality Stats cycle printout tA-61  
 POSITION screen displays 5-23  
 Precision of 6-1  
 Troubleshooting accuracy problems B-5  
 Type of 6-2, A-53  
 Position Quality Stats cycle printout tA-61  
 Position Type 2 cycle printout A-61  
 POSITIONING MODE parameter 2-9, 4-10  
 Positioning parameters 5-7, 5-10, 6-5  
 Post-Nav II postprocessing program 5-4  
 Power A-1  
 POWER connect or A-1, A-2  
 Power failure A-57  
 Power gauge in main Status screen A-53  
 Power port A-2  
 Power-up parameters A-10  
 Precision of results 1-4  
 Precision positioning 1-8  
 preface xvii  
 Preplanned static survey  
 Antenna parameter A-48  
 Auto-survey timer 2-28  
 File names A-75  
 Log Data process 2-24  
 Parameter sets 5-7, 5-11, A-56  
 Sessions process 2-12

## Index

---

### Printout

- Cycle printout sA-59
- Single-shot printoutsA-62

Procedures 1-2, 1-4, 1-9, 1-10

Pseudorange correction2-18

PWR - I/O 1 connectorA-1, A-2, A-5, A-6, A-7

PWR 2&3 connectorA-1, A-2, A-6, A-7

### Q

QA/QC Option 6 -3, A-61

QuickPlan computer software A-47

Quick-release adapter and bayonetA-35

Quickstart static survey

Main Status screenA-55

Parameter set 5-7, 5-11

Procedure e2-6

### R

Radial-arm survey 2-9, 3-7

Radio data links5-3, 5-9, 5-17

RangepoleA-30

Raw L1 Data Message cycle printoutA-61

Raw Measurements cycle printout A-61

reader comment form ii

Receiver Setup Info single-shot printoutA-62

Receivers, table of f1-9

ReceiversProcedure s1-9

RECOMB.BAT batch file A-79

Reference mark 4-5, 4-6

Reference position

Differential GPS 5-10, 5-20

Static survey 2-9, 2-14, 2-34

Reinitializing kinematic survey 4-22, 4-24

related information xix

FaxBack xxi

Technical Assistance xx

update note sxx

Remote interface protocol parameter A-9

Resetting receiver memoryB-7

Restarting a session 5-21, A-57

Return to previous mark 4-25

revision notice ii

Rnn file name extensionA-76, A-78

RTCM104

Input 5-12

RTCM-104

Input 5-14

Main Status screen A-52

Output5-12, 5-15

Troubleshooting B-2

RTK (Real-Time Kinematic) survey 1-7, 6-1, 7-2

### S

Satellite Elevation Plot single-shot printoutA-62

Satellite tracking, troubleshooting B-5

Schedule Plot For All Sats single-shot printoutA-62

scope xvii

- 
- Seismic Controller 4-9, 5-2, A-31, B-6
  - Selective Availability 5-1
  - Serial port
    - Cables A-6
    - Configuring A-7
    - Connecting to external device A-6
    - Connectors A-2
    - External data logging through A-64
    - Troubleshooting B-1
  - Session Description 2-15
  - Session ID 2-15
  - Sessions process 2-12, 2-13
  - Sigma statistics 6-3
  - Single-frequency
    - Configuring receiver for A-12
    - Static survey 2-1, 2-2
  - Sleep mode 2-28
  - Serial file name extension A-76
  - Stakeout 1-7
  - Static survey
    - Defined 2-1
    - Differential GPS at same time as 2-34
    - Entering supplementary data A-13
    - Main Status screen during A-52
    - Non-survey data logging equivalent to 2-4
    - Occupation time 2-1
    - Other operations during 2-32
  - Station description 2-13
  - Station ID 2-13, 2-25
  - Station index 2-13
  - Station name 2-13
  - Status information
    - FastStatic survey 3-9, 3-15
    - Kinematic survey 4-23
    - NAVSTAR system 1-12
    - Stop-and-go kinematic survey 4-1, 4-19
    - Supplementary data (event marks, etc.) A-13
    - Surface meteorological data A-18
    - Survey Controller 4-9, 5-2, A-31, B-6
    - Survey mark 4-6, 4-19
    - Sync time
      - Radio damage if too short 5-9
      - Static survey 2-34
- T**
- TAC xx
  - Technical Assistance xx
  - Technical support B-7
  - Time, local time & time zone
    - display A-19
  - Serial file name extension A-76
  - Topographic survey 2-6
  - trademarks iii
  - Tribrach A-22
  - Trimble Assistance Center (TAC) 1-12, B-7
  - Trimble Technical Assistance Center
    - TAC xx
  - TRIMTALK 900 transceiver 5-17
  - TRIMVEC Plus postprocessing
    - program 2-2, 4-8
  - Tripod A-22, A-30
  - Troubleshooting B-1
  - Two Serial Port Option A-2, A-6

**U**

Uncorrected height of antenna

    Modular Antenna A -42

    Rangepole A-34

    Tripod A -23, A-24

Universal Time Coordinated (UTC) A -  
    19

update no tesxx

**V**

Velocity, display of 6-16

**W**

warnings x x ii

Waypoint 6-6, 6-7, 6-12, 6-15

WGS-84 datum A-20

**Z**

Zone 6-4, A-20